

इंटरनेट

मानक

### Disclosure to Promote the Right To Information

Whereas the Parliament of India has set out to provide a practical regime of right to information for citizens to secure access to information under the control of public authorities, in order to promote transparency and accountability in the working of every public authority, and whereas the attached publication of the Bureau of Indian Standards is of particular interest to the public, particularly disadvantaged communities and those engaged in the pursuit of education and knowledge, the attached public safety standard is made available to promote the timely dissemination of this information in an accurate manner to the public.

“जानने का अधिकार, जीने का अधिकार”

Mazdoor Kisan Shakti Sangathan

“The Right to Information, The Right to Live”

“पुराने को छोड़ नये के तरफ”

Jawaharlal Nehru

“Step Out From the Old to the New”

IS 13026 (1991): bitumen mastic for flooring for industries handling LPG and other light hydrocarbon products [CED 5: Flooring, Wall Finishing and Roofing]



“ज्ञान से एक नये भारत का निर्माण”

Satyanarayan Gangaram Pitroda

“Invent a New India Using Knowledge”



“ज्ञान एक ऐसा खजाना है जो कभी चुराया नहीं जा सकता है”

Bhartrhari—Nitiśatakam

“Knowledge is such a treasure which cannot be stolen”



BLANK PAGE



IS 13026 : 1991  
REAFFIRMED 2006

भारतीय मानक

द्रवित पेट्रोलियम गैस तथा हल्के हाइड्रोकार्बन उत्पादों के  
प्रहस्तन में लगे उद्योगों के फर्श के लिए बिटुमेन मैस्टिक -  
विशिष्ट

*Indian Standard*

BITUMEN MASTIC FOR FLOORING FOR  
INDUSTRIES HANDLING LPG AND  
OTHER LIGHT HYDROCARBON  
PRODUCTS — SPECIFICATION

UDC 692.533.12: 662.767 013 5

© BIS 1991

BUREAU OF INDIAN STANDARDS  
MANAK BHAVAN, 9 BAHADUR SHAH ZAFAR MARG  
NEW DELHI 110002

April 1991

Price Group 3

**AMENDMENT NO. 1 JANUARY 1993**  
**TO**  
**IS 13026 : 1991 BITUMEN MASTIC FOR FLOORING**  
**FOR INDUSTRIES HANDLING LPG AND OTHER**  
**LIGHT HYDROCARBON PRODUCTS —**  
**SPECIFICATION**

*( Page 1, clause 5.1.2, line 2 ) — Substitute 'carbon' for 'certain'.*

*( Page 1, clause 6.2, line 4 ) — Substitute ' $5 \times 10^4$  ohms' for ' $5 \times 14^4$  ohms'*

( CED 5 )

Reprography Unit, BIS, New Delhi, India

## Flooring, Wall Finishing and Roofing Sectional Committee, CED 5

### FOREWORD

This Indian Standard was adopted by the Bureau of Indian Standards, after the draft finalized by the Flooring, Wall Finishing and Roofing Sectional Committee had been approved by the Civil Engineering Division Council.

This standard has been formulated with a view to laying down a new specification for bitumen mastic flooring for areas where light hydrocarbon products are handled. In the petroleum industry, bitumen mastic particularly of anti-static, electrically conducting grade is used extensively for the flooring of LPG bottling plants and other such areas, to ensure that no sparks are produced not only due to production of static electricity, but also due to impact of LPG cylinders and other metallic objects with the flooring.

Bitumen suitably incorporated with certain materials can be made to acquire electrically conductive and anti-static properties. One of the materials commonly used in bitumen mastics is carbon black/graphite.

It is known that for anti-static purposes, the discharge path through a product should normally have an upper limit of electrical resistance around  $5 \times 10^4$  ohms to give adequate protection against fire and dangerous electric shock, if the equipment becomes defective when operated at voltages up to 250 V. Hence, the carbon black/graphite content in the bitumen mastic should be adjusted to this level. In addition to this the requirement of impact, sparking resistance can be stated to be achieved if the finished flooring, while being sufficiently hard as to leave minimum local indentations on impact, should be resilient enough for these indentations to recover and substantially heal up in the course of time, and also no spark is produced due to such impact. These properties have to be achieved by adjusting the proportion of various ingredients in the bitumen mastic.

This standard shall be read in conjunction with IS 8374 : 1977 Specification for bitumen mastic, anti-static and electrically conducting grade, IS 1196 : 1978 Code of practice for laying bitumen mastic flooring. To provide guidance for preparation of base, laying of bitumen mastic flooring conforming to this standard, an Indian Standard IS 13974 : 1991 'Code of practice for laying of bitumen mastic flooring for industries handling LPG and other light hydrocarbon products' has been formulated.

For the purpose of deciding whether a particular requirement of this standard is complied with, the final value, observed or calculated, expressing the result of a test or analysis, shall be rounded off in accordance with IS 2 : 1960 'Rules for rounding off numerical values (*revised*)'. The number of significant places retained in the rounded off value should be the same as that of the specified value in this standard.

## Indian Standard

# BITUMEN MASTIC FOR FLOORING FOR INDUSTRIES HANDLING LPG AND OTHER LIGHT HYDROCARBON PRODUCTS — SPECIFICATION

### 1 SCOPE

**1.1** This standard specifies requirements of bitumen mastic flooring for industries handling LPG and other light hydrocarbon products.

**1.2** This standard is also applicable for explosive and crackers manufacturing factories, ordinance factories, ammonia depots, etc.

**1.3** This standard is not applicable for less volatile materials such as kerosene, diesel and lubricating oil.

### 2 REFERENCES

**2.1** The Indian Standards listed in Annex A are necessary adjuncts to this standard.

### 3 TERMINOLOGY

**3.1** For the purpose of this standard, terminologies given in IS 334 : 1982 and that given below shall apply

#### 3.2 Anti-Static

Having a resistance in the range of  $5 \times 10^4$  ohms to  $2 \times 10^8$  ohms

### 4 MATERIALS

#### 4.1 Bitumen

Properties of bitumen conforming to IS 702 : 1988 shall be as specified in Table 1.

**Table 1 Physical Properties of Bitumen**  
( Clause 4.1 )

Sl No.	Characteristic	Requirement	Method of Test
(1)	(2)	(3)	(4)
i)	Softening point ( ring and ball method )	65 to 100°C	IS 1205 : 1978
ii)	Penetration at 27°C in 1/100 cm	10 to 40	IS 1203 : 1978
iii)	Loss on heating, %	Max 0.3	IS 1212 : 1978
iv)	Solubility in CS <sub>2</sub> , %	Min 99	IS 1216 : 1978
v)	Ductility at 27°C, Min	2	IS 1208 : 1978

#### 4.2 Aggregates and Fillers

Aggregates and fillers used in preparing bitumen mastic should be lime stone and other carbon black/graphite materials. The lime stone should have calcium carbonate content of maximum

75 percent. The combined grading of aggregates shall be as specified in Table 2.

**Table 2 Grading of Aggregates and Fillers**

Sieve Designation		Percentage by Mass
Passing IS Sieve	Retained on IS Sieve	
90 microns	—	45 to 55
212 microns	90 microns	10 to 30
600 microns	212 microns	10 to 30
2.36 mm	600 microns	5 to 20
—	2.36	Nil

### 5 COMPOSITION

**5.1** Bitumen mastic composition is made by adding suitable materials like carbon black/graphite of conducting type.

**5.1.1** The bitumen content shall be between 13 and 18 percent by mass of the total mastics.

**5.1.2** Carbon black/graphite content shall be finer than 90 micron IS sieve with certain content more than 60 percent by mass.

#### 5.2 Preparation of Bitumen Mastic

**5.2.1** The aggregates and fillers shall be heated in a mastic cooker to a temperature of 120 to 150°C and then the required quantity of bitumen heated to 170 to 180°C added to it. These shall be mixed and cooked for about 3 hours until the homogeneous mass is obtained taking care that the temperature does not exceed 205°C at any time.

### 6 PROPERTIES

**6.1** The hardness number of bitumen mastic as laid and tested as per method described in Annex B shall be 4 to 12 at 35°C.

**6.2** The resistance of products after being manufactured according to 5.2 and when tested in accordance with 7 shall have electrical resistance between  $5 \times 10^4$  ohms and  $2 \times 10^8$  ohms.

### 7 TEST PROCEDURE FOR MEASURING ELECTRICAL RESISTANCE

#### 7.1 Preparation of Sample

In preparing sample for test, mastic as laid shall be filled directly from the mixer at the time of

**IS 13026 : 1991**

laying, into moulds which are not less than 100 mm in diameter or 100 mm square and float finished.

The sample, which shall be taken in duplicate, shall be moulded to a thickness of 25 mm. Where it is necessary to perform test on samples taken out from the floor, special precautions should be taken to ensure that the base is level and the sample is of uniform thickness. The sample should not be remelted.

**7.2 Preparation of the Surface**

The surface to be used in test shall be cleaned by rubbing with dry Fuller's earth using a clear pad of cotton wool, care being taken to avoid straining the material.

**7.2.1** After all traces of the powder have been cleaned away, the surfaces shall be wiped over with a pad moistened with distilled water and rubbed dry with a clean cloth.

**7.3 Test Procedure**

Immediately after the preparation of the surface, liquid electrodes and metal contacts as described in Annex C shall be applied as given in Annex D. It shall then be kept at a temperature of  $27 \pm 2^\circ\text{C}$  at a relative humidity of less than 70 percent, and the resistance test as specified in Annex D shall be carried out after a period of not less than 15 minutes or more than two hours. As some materials are sensitive to moisture, great care shall be taken to avoid breathing on the samples prior to and during the resistance test.

**ANNEX A**  
( Clause 2.1 )

**LIST OF REFERRED INDIAN STANDARDS**

<i>IS No.</i>	<i>Title</i>	<i>IS No.</i>	<i>Title</i>
334 : 1982	Glossary of terms relating to bitumen and tar ( <i>second revision</i> )	1208 : 1978	Methods of testing tar and bituminous materials: Determination of ductility ( <i>first revision</i> )
702 : 1988	Industrial bitumen ( <i>second revision</i> )	1212 : 1978	Methods of testing tar and bituminous materials: Determination of loss on heating ( <i>first revision</i> )
1203 : 1978	Methods of testing tar and bituminous materials: Determination of penetration ( <i>first revision</i> )	1216 : 1978	Methods of testing tar and bituminous materials: Determination of solubility in carbon disulphide or trichloroethylene ( <i>first revision</i> )
1205 : 1978	Methods of testing tar and bituminous materials: Determination of softening point ( <i>first revision</i> )		

**ANNEX B**  
( Clause 6.1 )

**METHOD FOR DETERMINING HARDNESS NUMBER**

**B-1 DEFINITION OF HARDNESS NUMBER**

**B-1.1** The hardness number is the figure denoting the depth, in hundredths of a centimetre, to which a flat-ended indentation pin in the form of a steel rod 6.35 mm in diameter will penetrate the mastic under a load of 317 N, applied for 1 minute, the temperature being maintained at  $35^\circ \pm 0.5^\circ\text{C}$ . This load is equivalent to  $10 \text{ N/mm}^2$  and is conveniently applied by means of a lever giving a suitable mechanical advantage.

**B-2 APPARATUS**

**B-2.1** The apparatus employed should be capable of fulfilling the above requirements accurately.

One convenient form of apparatus is shown in Fig. 1.

**B-3 METHOD**

**B-3.1** In order to ensure that the test results are reproducible, particular attention is called to the points given in **B-3.1.1** to **B-3.1.5**.

**B-3.1.1 Samples**

In preparing samples for test, the mastic as laid shall be filled directly from the mixer at the time of laying, into moulds which are not less than 100 mm in diameter or 100 mm square and float finished. The samples, which shall be taken in duplicate, shall be moulded to a thickness



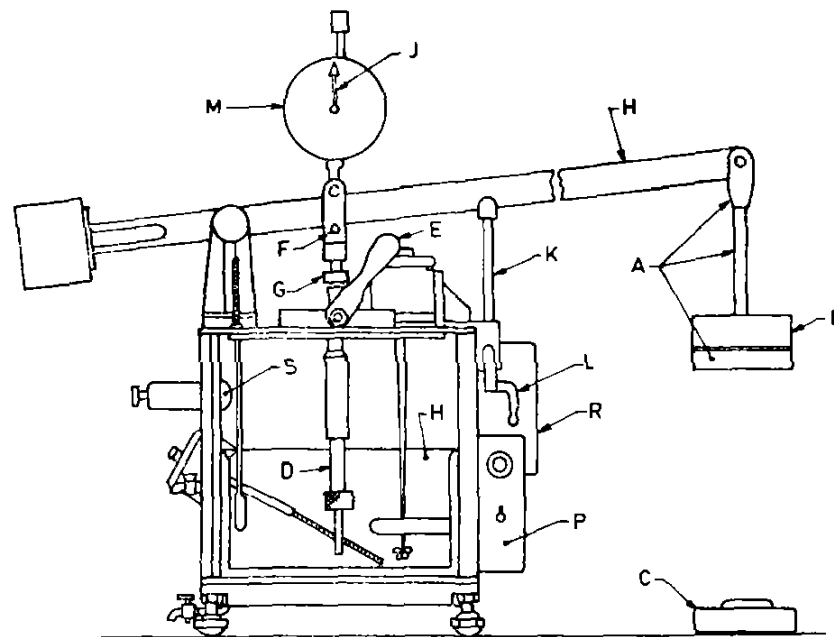

- |                             |   |
|-----------------------------|---|
| A — Yoke, stalk and tray    | J — Indicating needle                       |
| B — Weight ( central hole ) | K — Beam support yoke                       |
| C — Weight ( slotted )      | L — Support bracket                         |
| D — Indentor pin spindle    | M — Calibrated dial                         |
| E — Lock lever              | N — Water bath                              |
| F — Spindle head            | P — Control for water stirrer               |
| G — Adjusting nut           | R — Control for heater blade and thermostat |
| H — Beam                    | S — Bath illuminator                        |

FIG. 1 A TYPE OF APPARATUS FOR HARDNESS TESTING

of 25 mm. Where it is necessary to make a test on samples cut from the floor, special precautions should be taken to ensure that the sample is of uniform thickness and that the base is level. The samples should not be remelted.

#### B-3.1.2 Test Temperature

For the purpose of this standard, the sample shall be cooled for not less than three hours in air or not less than one hour in cold running water. It shall then be immersed in water at a temperature of  $35 \pm 0.5^\circ\text{C}$  for at least one hour immediately prior to testing and shall be maintained at that temperature during the test.

#### B-3.1.3 Adjustment of Pin

Before the load is applied, the indentation pin shall be adjusted lightly but firmly in contact with

the surface. The pressure should not be greater than necessary to prevent lateral movement of the specimen.

#### B-3.1.4 Testing

The requisite load shall then be applied for exactly 1 minute and the depth of indentation recorded in hundredths of a centimetre.

#### B-3.1.5 Test Results

Test points shall be not less than 25 mm apart and not less than 25 mm from the edge. At least five readings shall be taken and the results averaged. If any result differs from the mean by more than two hardness determined, except that if there are fewer than four results to be averaged the sample shall be discarded and the test shall be made on another samples.

**ANNEX C**  
( Clause 7.3 )

**LIQUID ELECTRODES AND CONTACTS AND TESTING INSTRUMENTS**

**C-1 LIQUID ELECTRODES**

**C-1.1** Liquid electrodes shall be formed on the surface by means of a conducting liquid.

**C-1.1.1** This shall consist of:

Anhydrous polyethylene glycol of mol wt 600	800 parts
Water	200 parts
Soft soap	1 part
Potassium chloride	10 parts

**C-1.1.2** The electrode area shall be completely wetted and remain so until the end of the test.

**C-1.1.3** Clean metal contacts shall be applied to the wetted areas so that the contact area is approximately of the same size as but not greater than the wetted area. The arrangement of the electrodes is shown in Fig 2.

**C-1.1.4** The surface of the product shall not be deformed either during the application of the contacts or during the test.

**C-2 TESTING INSTRUMENTS**

**C-2.1** The test shall be carried out with an insulation tester having a nominal open circuit voltage of 500 V d.c. or, with any suitable instrument known to give comparable results. For values of resistance above  $10^6$  ohms, an instrument with a nominal open circuit voltage of 1 000 V d.c. may be used.

The instrument shall be sufficiently accurate to determine the resistance within 5 percent and shall not dissipate more than 3 W in the specimen. The voltage shall be applied for no longer than is necessary to carry out the test in order to reduce the risk of overheating the test piece.

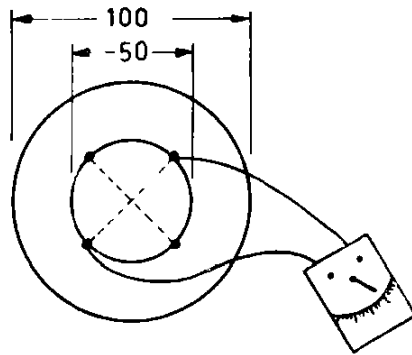

2A Testing of Circular Sample

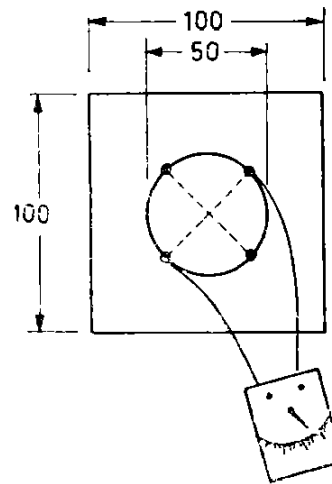

2B Testing of Square Sample

All dimensions in millimetres.

FIG. 2 TESTING OF ELECTRICAL RESISTANCE ON THE SURFACE

**ANNEX D**  
( Clause 7.3 )

**TESTS FOR ELECTRICAL RESISTANCE FOR BITUMEN MASTIC FLOOR**

**D-1 PROCEDURE**

**D-1.1** The test is performed on one surface. Apply liquid electrodes to two areas, each approximately 25 mm<sup>2</sup>, located on the same surface to be tested and situated so that the dry distance between the facing edges is 50 ± 6 mm.

Apply the metal contacts to the wetted areas and measure the resistance.

**D-1.2** This test shall also be performed on the sample to measure the electrical resistance across the surface. The arrangement of the electrodes to measure electric resistance across the surface is shown in Fig. 3.

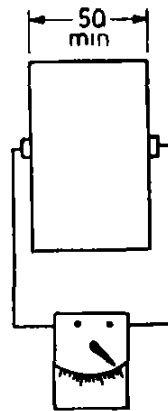

FIG. 3 TESTING ( SAMPLE THICKER THAN 50 mm ) FOR ELECTRICAL RESISTANCE ACROSS THE SURFACE

**Standard Mark**

The use of the Standard Mark is governed by the provisions of the *Bureau of Indian Standards Act, 1986* and the Rules and Regulations made thereunder. The Standard Mark on products covered by an Indian Standard conveys the assurance that they have been produced to comply with the requirements of that standard under a well defined system of inspection, testing and quality control which is devised and supervised by BIS and operated by the producer. Standard marked products are also continuously checked by BIS for conformity to that standard as a further safeguard. Details of conditions under which a licence for the use of the Standard Mark may be granted to manufacturers or producers may be obtained from the Bureau of Indian Standards.

## **Bureau of Indian Standards**

**BIS is a statutory institution established under the *Bureau of Indian Standards Act, 1986* to promote harmonious development of the activities of standardization, marking and quality certification of goods and attending to connected matters in the country.**

### **Copyright**

**BIS has the copyright of all its publications. No part of these publications may be reproduced in any form without the prior permission in writing of BIS. This does not preclude the free use, in the course of implementing the standard, of necessary details, such as symbols and sizes, type or grade designations. Enquiries relating to copyright be addressed to the Director ( Publication ), BIS.**

### **Revision of Indian Standards**

**Indian Standards are reviewed periodically and revised, when necessary and amendments, if any, are issued from time to time. Users of Indian Standards should ascertain that they are in possession of the latest amendments or edition. Comments on this Indian Standard may be sent to BIS giving the following reference :**

**Doc : No. CED 5 ( 4357 )**

### **Amendments Issued Since Publication**

<b>Amend No.</b>	<b>Date of Issue</b>	<b>Text Affected</b>

## **BUREAU OF INDIAN STANDARDS**

### **Headquarters :**

**Manak Bhavan, 9 Bahadur Shah Zafar Marg, New Delhi 110002**  
**Telephones : 331 01 31, 331 13 75**

**Telegrams : Manaksanstha**  
**( Common to all Offices )**

### **Regional Offices :**

**Central : Manak Bhavan, 9 Bahadur Shah Zafar Marg**  
**NEW DELHI 110002**

**Telephone**

**{ 331 01 31**  
**{ 331 13 75**

**Eastern : 1/14 C.I.T. Scheme VII M, V.I.P. Road, Maniktola**  
**CALCUTTA 700054**

**37 86 62**

**Northern : SCO 445-446, Sector 35-C, CHANDIGARH 160036**

**53 38 43**

**Southern : C.I.T. Campus, IV Cross Road, MADRAS 600113**

**41 29 16**

**Western : Manakalaya, E9 MIDC, Marol, Andheri ( East )**  
**BOMBAY 400093**

**6 32 92 95**

**Branches : AHMADABAD. BANGALORE. BHOPAL. BHUBANESHWAR.**  
**COIMBATORE. FARIDABAD. GHAZIABAD. GUWAHATI.**  
**HYDERABAD. JAIPUR. KANPUR. PATNA. THIRUVANANTHAPURAM.**