

इंटरनेट

मानक



Disclosure to Promote the Right To Information

Whereas the Parliament of India has set out to provide a practical regime of right to information for citizens to secure access to information under the control of public authorities, in order to promote transparency and accountability in the working of every public authority, and whereas the attached publication of the Bureau of Indian Standards is of particular interest to the public, particularly disadvantaged communities and those engaged in the pursuit of education and knowledge, the attached public safety standard is made available to promote the timely dissemination of this information in an accurate manner to the public.

“जानने का अधिकार, जीने का अधिकार”

Mazdoor Kisan Shakti Sangathan

“The Right to Information, The Right to Live”

“पुराने को छोड़ नये के तरफ”

Jawaharlal Nehru

“Step Out From the Old to the New”

IS 2542-1-1 to 12 (1978): Methods of Test for Gypsum Plaster, Concrete and Products, Part I: Plaster and Concrete [CED 4: Building Limes and Gypsum Products]

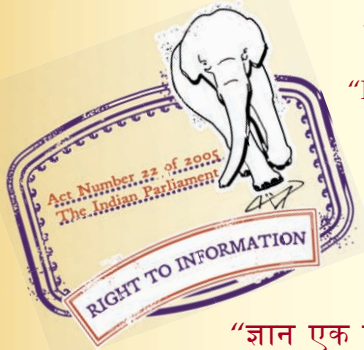

“ज्ञान से एक नये भारत का निर्माण”

Satyanarayan Gangaram Pitroda

“Invent a New India Using Knowledge”



“ज्ञान एक ऐसा खजाना है जो कभी चुराया नहीं जा सकता है”

Bhartrhari—Nitiśatakam

“Knowledge is such a treasure which cannot be stolen”

BLANK PAGE



IS : 2542 (Part 1/Sec 1 to 12) - 1978
(Reaffirmed 2002)

Indian Standard

**METHODS OF TEST FOR GYPSUM
PLASTER, CONCRETE AND PRODUCTS**

PART I PLASTER AND CONCRETE

(First Revision)

UDC 691.311 : 620.1

© BIS 2005

BUREAU OF INDIAN STANDARDS
MANAK BHAVAN, 9 BAHADUR SHAH ZAFAR MARG
NEW DELHI 110002

Price Group 8

Indian Standard

METHODS OF TEST FOR GYPSUM
PLASTER, CONCRETE AND PRODUCTS

PART I PLASTER AND CONCRETE

(*First Revision*)

Gypsum Building Materials Sectional Committee, BDC 21

Chairman

DR S. K. CHOPRA

Representing

Cement Research Institute of India, New Delhi

Members

ADDITIONAL DIRECTOR (ARCH), Ministry of Railways

RESEARCH, DESIGN AND STAND-
ARDS ORGANIZATION, LUCKNOW

JOINT DIRECTOR (ARCH) (*Alternate*)

SHRI N. G. BASAK

Directorate General of Technical Development,
New Delhi

SHRI K. D. BHARGAVA

Directorate of Mines & Geology, Government of
Rajasthan, Jaipur

MINING ENGINEER (*Alternate*)

SHRI K. K. BHATIA

All India Pottery Manufacturer's Association,
Calcutta

SHRI R. K. BHATNAGAR

Shri Ram Institute for Industrial Research, Delhi

SHRI C. P. SHARDA (*Alternate*)

SHRI A. M. BUTT

J & K Minerals Limited, Jammu Tawi

SHRI B. L. THAPPA (*Alternate*)

SHRI G. J. CHANDAK

Geological Survey of India, Calcutta

SHRI P. N. MEHTA (*Alternate*)

SHRI J. S. FRANCISCO

Jamnagar Mineral Development Syndicate, Jamnagar

DR S. K. GUHA

Central Glass & Ceramic Research Institute (CSIR),
Calcutta

SHRI S. N. GHOSH (*Alternate*)

SHRI K. K. MADAN

Delhi Development Authority, New Delhi

SHRI HAZARI LAL MARWAH

Central Builder's Association (Regd), Delhi

SHRI AMARJIT SINGH CHOUDHRY (*Alternate*)

SHRI K. C. MITAL

Rajasthan Housing Board, Jaipur

SHRI B. G. SHARMA (*Alternate*)

(*Continued on page 2*)

© BIS 2005

BUREAU OF INDIAN STANDARDS

This publication is protected under the *Indian Copyright Act* (XIV of 1957) and reproduction in whole or in part by any means except with written permission of the publisher shall be deemed to be an infringement of copyright under the said Act.

IS : 2542 (Part I/Sec 1 to 12) - 1978

(Continued from page 1)

<i>Members</i>	<i>Representing</i>
SHRI D. MOHTA	Raj Plasters Ltd, Bikaner
SHRI L. RAMIAH	Gypsum Industries Pvt Ltd, Tiruchirapalli
DR A. V. R. RAO	National Buildings Organization, New Delhi
SHRI G. T. BHIDE (<i>Alternate</i>)	
SHRI M. V. S. RAO	Engineer-in-Chief's Branch, Army Headquarters
SHRI V. K. RAZDAN (<i>Alternate</i>)	
SHRI M. N. ROY	Rajasthan State Mines & Minerals Ltd, Jaipur
SHRI L. T. P. SINHA	Development Commissioner, Small Scale Industries, New Delhi
DR C. A. TANEJA	Central Building Research Institute (CSIR), Roorkee
DR IRSHAD MASOOD (<i>Alternate</i>)	
SHRI H. C. VERMA	Associated Instrument Manufacturers (India) Pvt Ltd, New Delhi
SHRI A. V. R. SHASTRI (<i>Alternate</i>)	
SHRI D. AJITHA SIMHA, Director (Civ Engg)	Director General, ISI (<i>Ex-officio Member</i>)

Secretary

SHRI J. VENKATARAMAN
Deputy Director (Civ Engg), ISI

CONTENTS

	PAGE
FOREWORD	5
IS : 2542 (PART I)-1978 METHODS OF TEST FOR GYPSUM PLASTER, CONCRETE AND PRODUCTS: PART I PLASTER AND CONCRETE (<i>First Revision</i>):	
Section 1 NORMAL CONSISTENCY OF GYPSUM PLASTER	7
Section 2 NORMAL CONSISTENCY OF GYPSUM CONCRETE	9
Section 3 SETTING TIME OF PLASTER AND CONCRETE	11
Section 4 TRANSVERSE STRENGTH OF GYPSUM PLASTER	15
Section 5 COMPRESSIVE STRENGTH AND DRY SET DENSITY OF GYPSUM PLASTER	21
Section 6 SOUNDNESS OF GYPSUM PLASTER	23
Section 7 MECHANICAL RESISTANCE OF GYPSUM PLASTER BY DROPPING BALL TEST	25
Section 8 FREEDOM FROM COARSE PARTICLES	29
Section 9 EXPANSION OF PLASTER	31
Section 10 SAND IN SET PLASTER	33
Section 11 WOOD FIBRE CONTENT IN WOOD FIBRE GYPSUM PLASTER	37
Section 12 DRY BULK DENSITY	39

As in the Original Standard, this Page is Intentionally Left Blank

Indian Standard

METHODS OF TEST FOR GYPSUM PLASTER, CONCRETE AND PRODUCTS

PART I PLASTER AND CONCRETE

(First Revision)

0. FOREWORD

0.1 This Indian Standard (First Revision) was adopted by the Indian Standards Institution on 28 September 1978, after the draft finalized by the Gypsum Building Materials Sectional Committee had been approved by the Civil Engineering Division Council.

0.2 A number of Indian Standards on gypsum building materials covering specifications, code of practices, etc, have been prepared with a view to assisting the gypsum industry in its development. The standard on Methods of test on gypsum building materials has been prepared in two parts as follows:

Part I Plaster and concrete

Part II Gypsum products

0.3 This part (Part I) was first published in 1964 and has now been revised in the light of the experience gained in the use of the standard over these years and consequent to the revision of IS : 2547 (Part I)-1976* and IS : 2547 (Part II)-1976†. A number of changes have been incorporated in this revision and new methods of test, such as determination of setting time by potentiometer, determination of bulk density, and determination of dry set density, have been introduced.

0.3.1 While revising the standard, the various methods of tests applicable to gypsum plaster and concrete are being issued as separate sections of IS : 2542 (Part I), for the sake of facility of using these methods of tests and for keeping them up-to-date.

0.4 The properties of gypsum plaster and concrete are greatly affected by small amounts of impurities that may be introduced by careless

*Specification for gypsum building plaster: Part I Excluding premixed lightweight plasters (*first revision*).

†Specification for gypsum building plaster: Part II Premixed lightweight plasters (*first revision*).

IS : 2542 (Part I/Sec 1 to 12) - 1978

laboratory manipulation. In order to obtain concordant results, it is essential to observe the following precautions:

- a) All apparatus shall be kept thoroughly clean. Especially, all traces of set plaster shall be removed.
- b) Distilled water (*see* IS : 1070-1977*) free from chlorides and sulphates, at a temperature of $27 \pm 2^{\circ}\text{C}$ shall be used for mixing putties and mortars.
- c) Standard sand conforming to IS : 650-1966† where specified shall be used. The sand shall be stored in closed containers.

0.5 In the formulation of this standard due weightage has been given to international co-ordination among the standards and practices prevailing in different countries in addition to relating it to practices in the field in this country.

0.6 This edition incorporates Amendment issued to Section 8, detail of which is indicated in that mention as well as in the last cover page. Side bar indicates modification of the text as the result of incorporation of this amendment.

0.7 In reporting the results of a test or analysis made in accordance with this standard, if the final value, observed or calculated, is to be rounded off, it shall be done in accordance with IS : 2-1960‡.

*Specification for water for general laboratory use (*second revision*).

†Specification for standard sand for testing of cement (*first revision*).

‡Rules for rounding off numerical values (*revised*).

Indian Standard

METHODS OF TEST FOR GYPSUM PLASTER, CONCRETE AND PRODUCTS

PART I PLASTER AND CONCRETE

Section I Normal Consistency of Gypsum Plaster

(First Revision)

1. SCOPE

1.1 This standard (Part I/Sec 1) covers the method of test for determining the normal consistency of gypsum plaster.

NOTE — Since accuracy in determining normal consistency is most important in standardizing physical methods of testing cementitious materials, it is essential that this test be performed with great care.

2. TERMINOLOGY

2.1 For the purpose of this standard, the definitions given in IS : 2469-1976* shall apply.

3. APPARATUS

3.1 Modified Vicat Apparatus — The modified Vicat apparatus shall generally conform to IS : 5513-1976† and shall have a movable brass tube, 6.3 mm in diameter and suitable length to fit the Vicat bracket. On the lower end of the tube shall be attached a conical plunger, made of aluminium with an apex angle of $53 \pm 0.5^\circ$ and a height of 45 ± 0.5 mm. The total mass of the tube and plunger shall be 35 ± 0.5 g. The total weight may be increased by means of a weight, screwed onto the tube. Suitable bushings shall be fixed in frame for properly guiding and aligning the movement of tube vertically. The mould (*see* IS : 5513-1976†) shall, however, be kept in an inverted position such that the inside diameter is 60 ± 0.5 mm at the base and 70 ± 0.5 mm at the top.

4. PROCEDURE

4.1 Clean the plunger, mould and base plate of the modified Vicat apparatus. Apply a thin coat of a petroleum jelly or other suitable

*Glossary of terms relating to gypsum (*first revision*).

†Specification for Vicat apparatus (*first revision*).

IS : 2542 (Part I/Sec 1) - 1978

lubricant on the upper surface of the base plate in order to prevent leaks during the test.

4.2 Sift a weighed quantity of the sample (200 to 300 g as required to fill the mould) into a known volume of water. If the plaster is unretarded, add to the mixing water 0.1 g of commercial retarder per 100 g of sample. After allowing the sample to soak for 2 minutes, stir the mixture for 1 minute to an even fluidity. Pour this sample into the Vicat mould, work slightly to remove air bubbles, and then strike off flush with the top of the mould. Wet the plunger of the modified Vicat apparatus and lower it to the surface of the sample at approximately the centre of the mould. Read the scale and release the plunger immediately. After the rod has settled, read the scale again.

4.2.1 Readings are reproducible on a retarded mix, and, therefore, in order to eliminate error, two or three determinations should be made on each mix, care being taken to have the mould completely filled and the plunger clean and wet.

5. REPORT

5.1 Gypsum plaster shall be considered of normal consistency when a penetration of 30 ± 2 mm is obtained when tested in accordance with **4.1** and **4.2**, the mass of the rod and plunger for this determination to be 35 ± 0.5 g. Normal consistency shall be expressed as the number of millilitres of water required to be added to 100 g of the gypsum plaster.

5.2 All gypsum mixtures containing aggregates shall be considered of normal consistency when a penetration of 20 ± 3 mm is obtained when tested in accordance with **4.1** and **4.2**, the mass of rod and plunger for these determinations to be 50 ± 0.5 g. Normal consistency shall be expressed as the number of millilitres of water required to be added to 100 g of the mixture.

Indian Standard

METHODS OF TEST FOR GYPSUM
PLASTER, CONCRETE AND PRODUCTS

PART I PLASTER AND CONCRETE

Section 2 Normal Consistency of Gypsum Concrete

(First Revision)

1. SCOPE

1.1 This standard (Part I/Sec 2) covers the method of test for determining the normal consistency of gypsum concrete.

2. TERMINOLOGY

2.1 For the purpose of this standard, the definitions given in IS : 2469-1976* shall apply.

3. APPARATUS

3.1 Consistometer (see Fig. 1) — This shall consist of a conical vessel made of non-corroding, non-absorbent material, and shall have an inside diameter of 225 ± 2.5 mm at the top and 45 ± 2.5 mm at the bottom, and a height of 140 ± 1.5 mm. It shall be provided with a sliding gate at the bottom, and supported so that the bottom is 100 ± 1.5 mm above the base plate. The base plate shall be of plate glass, free from scratches and about 450 mm square.

4. PROCEDURE

4.1 The consistometer and the base plate shall be clean and dry and the sliding gate shall be closed.

4.2 Sift 2 000 g of the sample into a known volume of water to which 0.5 g of commercial retarder has previously been added. After allowing the sample to soak for 1 minute, stir the mixture for 3 minutes to an even fluidity. Pour the mixture into the consistometer until level with the top. Then rapidly and completely open the sliding gate, allowing the mixture to run out freely upon the base plate. When the sliding gate is opened, care shall be taken to avoid jarring the consistometer.

*Glossary of terms relating to gypsum (*first revision*).

AMENDMENT NO. 1 JUNE 1991
TO
IS 2542 (Part 1/Sec 3) : 1978 METHODS OF TEST FOR
GYPSUM PLASTER, CONCRETE AND PRODUCTS
PART 1 PLASTER AND CONCRETE
Section 3 Setting Time of Plaster and Concrete
(First Revision)

(Page 11, clause 1.2) — Delete.

(Page 13, clauses 6 , 7 and 8) — Delete.

(CED 21)

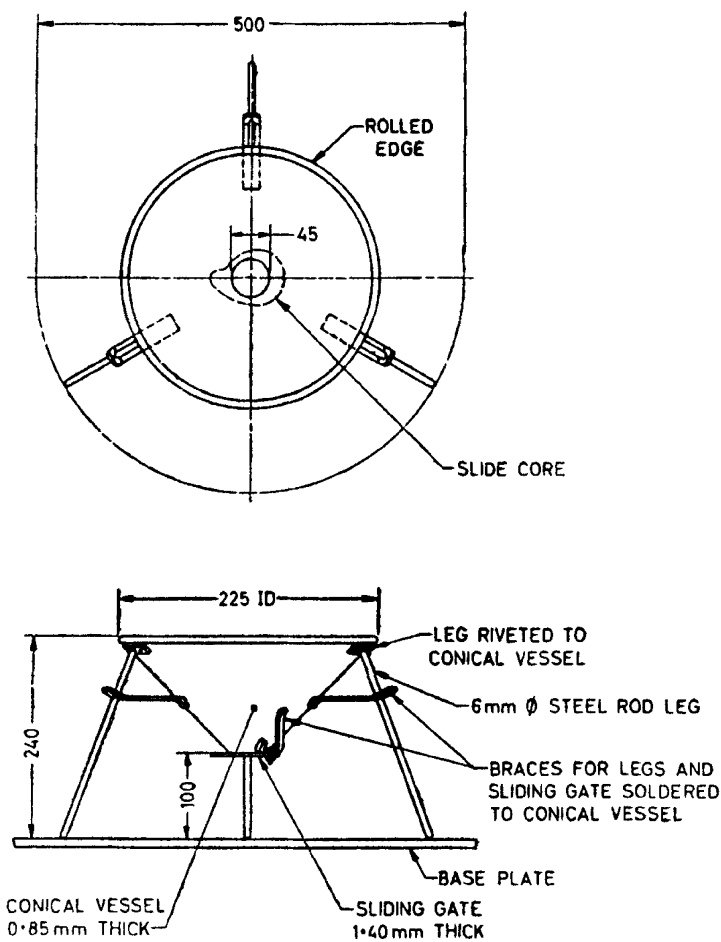

All dimensions in millimetres.

FIG. 1 CONSISTOMETER

4.3 Measure the resulting patty on the base plate along its major and minor axis and determine the average diameter.

5. REPORT

5.1 Gypsum concrete shall be considered of normal consistency when a patty diameter of 380 ± 15 mm is obtained when tested as described in 4. Normal consistency shall be expressed as the number of millilitres of water required to be added to 100 g of gypsum concrete.

Indian Standard

METHODS OF TEST FOR GYPSUM PLASTER, CONCRETE AND PRODUCTS

PART I PLASTER AND CONCRETE

Section 3 Setting Time of Plaster and Concrete

(First Revision)

1. SCOPE

1.1 This standard (Part I/Sec 3) covers the methods of test for determining the setting time of plasters and concrete.

1.2 Two methods have been described for determining the setting time of plaster and concrete. One method makes use of Vicat apparatus and the second method makes use of potentiometer.

2. TERMINOLOGY

2.1 For the purpose of this standard, the definitions given in IS : 2469-1976* shall apply.

3. VICAT APPARATUS METHOD

3.1 General — The Vicat apparatus including Vicat mould, needle and other attachments shall generally conform to 4 and Fig. 1 of IS : 5513-1976†.

4. PROCEDURE

4.1 Gypsum Concrete and All Gypsum Plaster, Except Gypsum Neat Plaster — Mix 200 g of the sample in such quantity of water as will give a paste of normal consistency (using the method of mixing given in Part I/Section 1, except that no retarder shall be used when conducting the test), pour into the Vicat mould, shake a few times to remove the air entrapped and level off flush with the top of the mould. Allow the needle to sink into the paste and remove it to the original position. After each penetration, wipe the needle clean and move the mould slightly so that the needle will not penetrate at the same point twice. Depending upon the character of the material, test the sample frequently at such intervals as are necessary to determine whether it

*Glossary of terms relating to gypsum (*first revision*).

†Specification for Vicat apparatus (*first revision*).

IS : 2542 (Part I/Sec 3) - 1978

complies with the requirements for time of setting for the product tested (*see* 4.3). Set shall be considered complete when the needle no longer penetrates to the bottom of the paste. Until set, store the test specimens in a cabinet at a temperature of $27 \pm 2^{\circ}\text{C}$ in an atmosphere having a relative humidity of 85 to 100 percent.

4.2 Gypsum Neat Plaster — Test gypsum neat plaster for time of setting as mixed with three parts by weight of standard sand conforming to IS : 650-1966*. Mix dry a 100 g sample of gypsum neat plaster and 300 g of the standard sand, and then add sufficient water to produce a mixture of normal consistency as described in Part I/Section 1. Place the mortar in the conical rings and test for the time of setting as described in 4.1.

NOTE 1 — Gypsum neat plaster is calcined gypsum plaster mixed with other ingredients to control working quality and setting time. The addition of aggregate is required on the job.

NOTE 2 — Determination of setting time of plaster of paris or retarded hemihydrate gypsum plaster may either be carried out on plaster sand mixture or neat plaster as described in 4.2 when carried out on plaster sand mixture, the ratio of plaster to sand conforming to IS : 650-1966* shall be 1 : 3.

4.3 Frequency of testing of the materials shall be as follows:

<i>Kind of Material</i>	<i>First Test</i>	<i>Frequency of Subsequent Tests</i>
Moulding plaster	15 min	5 min
<i>Keen's plaster:</i>		
a) Standard	15 min	1 h
b) Quick set	15 min	5 min
Gypsum concrete	15 min	5 min
Ready mixed plaster	1½ h	1 h
Neat plaster	2 h	1 h
Wood fibred plaster	1½ h	1 h
<i>Gauging plaster:</i>		
a) Slow set	40 min	2 h
b) Quick set	15 min	5 min

5. REPORT

5.1 Record as the time of setting of the sample the elapsed time in minutes from the time when the sample was first added to the water to the time when set is complete.

*Specification for standard sand for testing of cement (*first revision*).

6. POTENTIOMETER METHOD

6.1 Apparatus

6.1.1 Potentiometer — A single or multiple channel recording potentiometer or thermistor bridge shall be used to record the temperature change of the sample under test. The chart speed shall be at least 25 mm/h. Imprints recording the temperature shall not be longer than 1 min apart for each sample.

6.1.2 Temperature Sensors — The temperature changes may be indicated by either thermocouples or thermistors which may be movable or in a fixed position. Temperature sensing elements shall be of such capacity and sensitivity that when connected to the recording potentiometer, a temperature change of 0.5°C in the sample shall be recorded on the chart.

6.1.3 Sample Containers — Waxed paper cups from 178 to 268 ml capacity shall be used. The cup containing the mixture under test shall be placed inside a matching paper cup held in an insulated block or beaker; the movable temperature sensor, in this case, shall be positioned $\frac{1}{4}$ to $\frac{1}{3}$ the distance up from the bottom and between the inner and the outer cup. Alternatively, the cup containing the test mixture may be positioned over a spring-loaded sensor to assure close contact with the bottom of the cup.

7. PROCEDURE

7.1 Gypsum Concrete and All Gypsum Plaster, Except Gypsum Neat Plaster — Mix 200 g of the dry sample to a paste of normal consistency without using any retarder. Place the mixture in a clean dry waxed paper cup to about 19 mm from the top. Place the cup into the empty cup in the cup holder and adjust the sensing element as required in 6.1.3 or place the cup upon a spring loaded sensor. Cover the cup with a watch glass.

7.2 Gypsum Neat Plaster — Prepare the mixed plaster as required in 4.2. Fill a waxed paper cup and test as outlined in 7.1.

7.2.1 Temperature During Testing — Tests shall be made in room or cabinet maintained at a temperature of $27 \pm 2^\circ\text{C}$. Materials and mixing water used for the test shall be at $27 \pm 2^\circ\text{C}$.

NOTE — If a constant-temperature cabinet is not available, a constant temperature water bath may be fitted with a cover which will admit the body of the cup holder but not its rim, so that the cup holder is in contact with the water in the bath.

8. REPORT

8.1 Record as the time of setting of the sample the elapsed time in minutes from the time when the sample was first added to the water to the time of maximum temperature rise.

As in the Original Standard, this Page is Intentionally Left Blank

Indian Standard

METHODS OF TEST FOR GYPSUM PLASTER, CONCRETE AND PRODUCTS

PART I PLASTER AND CONCRETE

Section 4 Transverse Strength of Gypsum Plaster

(First Revision)

1. SCOPE

1.1 This standard (Part I/Sec 4) covers the procedure for determining the transverse strength of gypsum plaster.

2. TERMINOLOGY

2.1 For the purpose of this standard, the definitions given in IS : 2469-1976* shall apply.

3. METHOD OF DETERMINING TRANSVERSE STRENGTH

3.1 **Apparatus** — The apparatus shall consist of the following:

- a) *Moulds* — A six-compartmented metal mould for making specimens $100 \times 25 \times 25$ mm. The 25 mm dimensions of the mould shall be accurate within ± 0.05 mm when new and maintained within ± 0.1 mm. The internal faces of the mould sides shall be maintained plane to 0.01 mm over any 25 mm length and 0.04 mm overall. The mould shall be provided with a base of rectangular metal or glass plate $230 \times 150 \times 6$ mm thick, and sufficiently plane to make, when greased, watertight joint with the sides of the mould.
- b) *Damp Closet* — The atmosphere of the damp closet for the storage of the specimens shall be maintained at a relative humidity of at least 80 percent and at a temperature of $27 \pm 2^\circ\text{C}$.
- c) *Testing Machine* — An ordinary transverse testing machine can be adapted for this test by fitting appropriate clamps and adjusting the rate of loading (*see also 3.4*).

3.2 Standard Sand

3.2.1 The standard sand shall conform to IS : 650-1966†.

*Glossary of terms relating to gypsum (*first revision*).

†Specification for standard sand for testing of cement (*first revision*).

3.3 Preparation of Test Specimens

3.3.1 Plaster of Paris — Stabilize the plaster in accordance with the method given in Appendix A. Prepare six specimens as follows using a mix of neat plaster at a standard pourable consistency determined in advance as described below:

Sprinkle the plaster (a convenient quantity is 450 g) over the surface of the required amount of water over a period of 30 seconds. Allow to stand for 30 seconds and then stir for 60 seconds, after which time the mix shall be of uniform consistency throughout.

Immediately pour the mix into the moulds and vibrate the moulds by hand to remove air bubbles. Remove excess material, leaving slightly more than needed to fill the mould. The whole operation should be completed as soon as possible after mixing.

Allow the specimens to remain undisturbed in the moulds for 24 hours, under a damp cloth or in a damp closet. Scrape the top surface of the prisms smooth and level with the top of the mould. Remove the prisms from the mould dry to constant weight in a well-ventilated oven maintained at a temperature between 35°C and 40°C and test dry.

3.3.1.1 Standard pourable consistency — The apparatus consists of a hollow corrosion-resistant metal cylinder of internal diameter 30 mm and height 50 mm with the ends square to the longitudinal axis. It is centred on a metal base plate.

Over a period of 30 seconds sprinkle 100 g of the plaster over the surface of a known volume of water in which 0.1 g of sodium citrate has previously been dissolved. Allow to stand for 30 seconds and then stir for 60 seconds. Transfer the mixture to the metal cylinder and strike off level with the top. Thirty seconds after mixing is completed lift the cylinder vertically and allow the mixture to spread over the base plate.

Measure the maximum and minimum diameters of spread and record the mean.

NOTE — Mechanical devices may be used to control the rate of separation and to ensure that the cylinder is removed vertically. Alternatively, the cylinder may be clamped and the base plate lowered.

Repeat the procedure varying the ratio of plaster to water until a mixture of standard pourable consistency is obtained. Record the plaster-water ratio.

The standard pourable consistency corresponds to a mean diameter of spread of 78-80 mm.

3.3.2 Undercoat Plaster — Stabilize the plaster in accordance with the method given in Appendix A. Prepare six specimens with a mix of one

part plaster and three parts standard sand by weight gauged with water to standard undercoat consistency as follows:

A convenient quantity of plaster to use is 200 g. Mix the plaster with three times its weight of standard sand (*see 3.2*) for two minutes and gauge with water to produce a paste of the standard undercoat consistency defined below.

Determine the precise amount of water needed by previous trial (as a guide, first try between 14 percent and 17 percent of the total dry weight, that is, between 112 ml and 136 ml).

Add the dry sanded mix to the water over a period of 30 seconds and allow to soak for a further 30 seconds. Mix vigorously for one minute with a stiff bladed spatula to produce a paste of uniform consistency. Test the mix for consistency as described in **3.3.2.1**. If the consistency is correct, fill the mix immediately into the appropriate moulds; if it is not correct repeat the whole procedure using a different proportion of water.

Fill the mould to half height and consolidate the mix by tamping ten times with a 6 mm square brass rod along the length of the mould. Fill the mould above the top and consolidate the top layer in a similar manner.

Allow the specimens to remain undisturbed in the mould for 24 hours under a damp cloth or in a damp closet. Scrape the top surface of the plaster-prisms smooth and level with the top of the mould. Remove the prisms from the mould, dry to constant weight in a well ventilated oven maintained at a temperature between 35°C and 40°C and test dry.

3.3.2.1 Standard consistency — The standard testing consistency shall be determined by means of a dropping ball penetrometer test, as described below:

The paste under test shall be filled into a Vicat mould (*see IS : 5513-1976**). The mould shall rest on a non-porous plate; it shall be filled using only a flexible palette-knife or the like and the thumbs or fingers, introducing small quantities at a time and in such a manner as to eliminate voids or air bubbles. The surface of the paste shall be smoothed off level with the top of the mould.

A 25 mm diameter methylmethacrylate ball, weighing 9.8 ± 0.1 g shall then be dropped from rest from a height of 250 mm (measured from the bottom of the ball to the surface of the paste) on to the surface of the paste, so as to fall approximately in the centre of the mould. The distance from the lowest point of the ball to the level of the original surface of the material shall be recorded as the penetration.

*Specification for Vicat apparatus (*first revision*).

IS : 2542 (Part I/Sec 4) - 1978

A convenient method of measuring the depth of penetration is provided by the use of a bridge, which can rest on the rim of the mould, carrying in the centre a vertical sliding millimetre scale or micrometre, and measuring down to the top of the ball without removing the latter from its seat in the paste. An allowance of 25 mm should be made for the diameter of the ball (see Fig. 1).

The paste is of the correct consistency when the ball penetrates 9 to 10 mm.

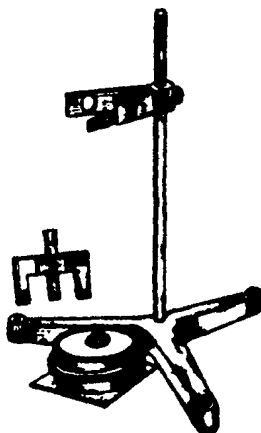

FIG. 1 METHOD OF MEASURING DEPTH AND PENETRATION

3.4 Transverse Strength Test — Test each of six specimens 25 mm square in cross section and 100 mm long. Place the specimen under test symmetrically on two parallel metal rollers 10 mm in diameter and located at 75 mm centres. Apply the load by a third parallel roller of the same size at a point midway between the other two. Do not use any packing between the rollers and the specimen, and place the specimen so that the faces in contact with the rollers are those which were cast against the sides of the mould.

Apply the load steadily and uniformly from zero, at a rate of not less than 2 000 kgf/min (200 N/min) and not more than 8 000 kgf/min (800 N/min).

3.5 Calculations of Results — Calculate the mean value of the breaking load of the six specimens and convert it to a modulus of rupture expressed in N/mm^2 . For the test conditions given, the value of the modulus is 0.007 2 times the value of the mean breaking load in Newtons.

APPENDIX A

(Clauses 3.3.1 and 3.3.2)

METHOD FOR STABILIZING PLASTER OF PARIS AND UNDERCOAT PLASTER

A-1. Plaster shall be stabilized before use in the tests for compressive strength, transverse strength, mechanical resistance and expansion on setting as below:

- a) For this purpose, the plaster shall be exposed for 24 hours in a layer not more than 12.5 mm in thickness to an atmosphere of 75 ± 3 percent relative humidity at a temperature of $27 \pm 2^{\circ}\text{C}$ with vigorous air circulation over the specimen throughout this period.
- b) The humidity may be maintained by a saturated solution of sodium chlorate contained together with the solid salt in a wide dish and placed in a tightly closed cabinet. The air in the cabinet should be kept moving over both solution and plaster.

As in the Original Standard, this Page is Intentionally Left Blank

Indian Standard

METHODS OF TEST FOR GYPSUM PLASTER, CONCRETE AND PRODUCTS

PART I PLASTER AND CONCRETE

Section 5 Compressive Strength and Dry Set Density of Gypsum Plaster

(First Revision)

1. SCOPE

1.1 This standard (Part I/Sec 5) covers the procedure for determining the compressive strength and dry set density of gypsum plaster.

2. TERMINOLOGY

2.1 For the purpose of this standard, the definitions given in IS : 2469-1976* shall apply.

3. APPARATUS

3.1 Cube Moulds — The moulds for 50 mm cube specimens shall be made of non-corrodible material and shall be of sufficient strength and stiffness to prevent spreading and warping. The moulds shall be rigidly constructed in such a manner as to facilitate the removal of the moulded specimen without damage. The moulds shall have not more than three compartments and shall be separable into not more than two parts. The moulds shall be machined so that when assembled ready for use the dimensions and internal faces shall be accurate to the following limits:

The height of the moulds and the distance between the opposite faces shall be 50 ± 0.1 mm for new moulds, and 50 ± 0.5 mm for moulds in use. The angle between adjacent interior faces and between interior faces and top and bottom planes of the mould shall be $90 \pm 0.5^\circ$. The interior faces of the moulds shall be plane surfaces with a permissible variation of 0.02 mm for new moulds and 0.05 mm for moulds in use. Each mould shall be provided with a base plate having a plane surface machined to a tolerance of 0.1 mm and made of non-absorbent and non-corrodible material. The base plate shall be of such dimensions as to support the mould during the filling without leakage.

3.2 Test Specimen

3.2.1 Stabilizing Premixed Lightweight Gypsum Plaster — Stabilize the plaster before use in tests as given in Appendix A of Part I/Section 4.

3.2.2 Mix sufficient sample at normal consistency (see Part I/Section 1) to produce not less than 1 000 ml of mixed mortar and cast into six 50-mm split cube moulds. Neat gypsum plaster shall be premixed dry

*Glossary of terms relating to gypsum (*first revision*).

IS : 2542 (Part I/Sec 5) - 1978

with two parts by weight of standard sand as in IS : 650-1966*. No retarder shall be added. Place the required amount of water in a clean 2.5 litre mixing bowl. The temperature of water shall be $27 \pm 2^\circ\text{C}$. For all gypsum plasters except gypsum concrete, add the required amount of dried plaster and allow to soak for 2 minutes. Mix vigorously for one minute with a metal spoon or stiff bladed spatula to produce a mortar of uniform consistency. For gypsum concrete, soak for 1 minute and stir vigorously (about 150 complete circular strokes per minute) with a large metal spoon for 3 minutes.

4. PROCEDURE

4.1 Determination of Dry Set Density — The mould shall be coated with a thin film of mineral oil and placed on an oiled glass or metal plate. Place a layer of mortar about 25 mm in depth in each mould and puddle ten times across the mould between each pair of opposite faces with a 25 mm wide metal spatula, to remove air bubbles. Fill the moulds to a point slightly above the tops of the moulds, by the same filling and puddling procedure used for the first operation. After the mortar or paste has set, cut off the excess to a plane surface flush with the top of the mould. Place the filled moulds in moist air (90 to 100 percent humidity). The cubes may be removed from the moulds as soon as thoroughly hardened, but shall be retained in the moist air not less than a total of 24 hours. Place the cubes in an oven provided with air circulation and adequate ventilation for removal of moisture so that the air may be maintained at a temperature of 30 to 45°C and a relative humidity not to exceed 50 percent. Dry the cubes to a constant weight as determined by weighing once each day but not to exceed 7 days. Weigh the six dry cubes and determine the dry set density in kg/m^3 .

4.2 Determination of Compressive Strength — As soon as the cube specimens have been dried, determine their compressive strengths. Position the cubes in the testing machine so that the load is applied on surfaces formed by faces of the moulds, not on top and bottom. Apply the load continuously and without shock at a constant rate within the range 1 to 4 kgf/cm^2 (98 to 392 kN/m^2) per second. During application of the first half of the maximum load a higher rate of loading shall be permitted.

4.2.1 The average compressive strength shall be reported as the compressive strength of the material except that if the strengths of one or two of the cubes vary more than 15 percent from the average of the five, they shall be discarded and the compressive strength shall be reported as the average of the remaining specimens. In case the compressive strengths of three or more cubes vary more than 15 percent from the average, the results shall be discarded and the test repeated.

NOTE — For compressive strength of gypsum concrete only $(50 \pm 0.2) \times (100 \pm 0.2)$ mm cylinder moulds may be used instead of cube moulds. Prepare the specimens as described in 3.2, except that the paste shall be struck off to a smooth surface flush with the tops of the moulds immediately after the moulds are filled. Test the specimens and report the results as described in 4.2.

*Specification for standard sand for testing of cement (*first revision*).

Indian Standard

METHODS OF TEST FOR GYPSUM PLASTER, CONCRETE AND PRODUCTS

PART I PLASTER AND CONCRETE

Section 6 Soundness of Gypsum Plaster

(First Revision)

1. SCOPE

1.1 This standard (Part I/Sec 6) covers the procedure for determining soundness of gypsum plaster.

2. TERMINOLOGY

2.1 For the purpose of this standard, the definitions given in IS : 2469-1976* shall apply.

3. TEST SPECIMENS

3.1 The soundness shall be determined by steaming six pats of neat plaster prepared as described in **3.3**. The moulds should be about 100 ± 1 mm in diameter and 6 ± 0.2 mm deep, well greased before use and resting on well greased non-porous base plates.

3.2 Plaster of Paris shall be gauged with the appropriate amount of water to produce a smooth cream, anhydrous gypsum plaster, retarded hemihydrate gypsum plaster and Keene's plaster with the appropriate amount of water to produce a stiff plastic paste convenient for filling the moulds. The flat pats shall be formed by pouring or pressing the material into the moulds in such a manner as to avoid air-bubbles, and smoothing off level with the top edge of the mould with a broad flexible palette-knife or the like.

3.3 Procedure — The pats shall be allowed to set undisturbed in air of at least 80 percent relative humidity for about 16 to 24 hours in case of plaster of Paris and retarded hemihydrate and for three days in the case of anhydrous gypsum plaster and Keene's plaster and then subjecting them to action of saturated steam at atmospheric pressure for a period of three hours without removing from the moulds and finally examining in a good light for signs of disintegration, popping or

*Glossary of terms relating to gypsum (*first revision*).

IS : 2542 (Part I/Sec 6) - 1978

pitting. The steamer shall be arranged so that condensed water cannot drip back on to the face of the pats.

3.4 Report — Whether the set plaster pats show signs of disintegration, popping or pitting shall be reported.

Indian Standard

METHODS OF TEST FOR GYPSUM PLASTER, CONCRETE AND PRODUCTS

PART I PLASTER AND CONCRETE

Section 7 Mechanical Resistance of Gypsum Plaster by Dropping Ball Test

(First Revision)

1. SCOPE

1.1 This standard (Part I/Sec 7) covers the procedure for determining the mechanical resistance of gypsum plaster.

2. TERMINOLOGY

2.1 For the purpose of this standard, the definitions given in IS : 2469-1976* shall apply.

3. APPARATUS

3.1 Ball — A clean and polished hard steel ball 12.7 mm in diameter, weighing 8.33 g.

3.2 Moulds — A six-compartmented metal mould for making specimens $100 \times 25 \times 25$ mm. The 25 mm dimensions of the mould shall be accurate within ± 0.05 mm when new and maintained within ± 0.1 mm. The internal faces of the mould sides shall be maintained plane to 0.01 mm over any 25 mm length and 0.04 mm overall. The mould shall be provided with a rectangular metal or glass plate $230 \times 150 \times 6$ mm thick and sufficiently plane to make, when greased, a water-tight joint with sides of the mould, to act as a base.

3.2.1 Damp-Closet — The atmosphere of the damp closet for the storage of the specimens shall be maintained at a relative humidity of at least 80 percent and at a temperature of $27 \pm 2^\circ\text{C}$.

3.2.2 Tube — straight, smooth, clean and dry approximately 16 mm in internal diameter and 1.72 m in length.

*Glossary of terms relating to gypsum (*first revision*).

4. TEST SPECIMEN

4.1 Retarded Hemihydrate Plaster (Final Coat Plaster) – Stabilize the plaster before test in accordance with the method described in Appendix A of Part I/Section 4. Prepare four test specimens as follows:

- a) A convenient quantity of plaster to use is 400 g. Add this over a period of 30 seconds to the appropriate amount of water to produce a standard final coat consistency, allow to soak for 1 minute and then mix with a stiff-bladed spatula for 2 minutes, after which time the mix shall be less uniform.
- b) Determine the precise quantity of water needed by a previous trial. The determination of the required standard final coat consistency is described in **4.3**.
- c) Fill the moulds in two layers, tamping each layer ten times with a 6 mm² brass rod along the length of the mould. Strike off the surface level with the top of the mould.
- d) Ensure that the specimens remain undisturbed in the moulds for 24 hours under a damp cloth or in a damp closet and then remove them from the moulds. Finally, dry them to constant weight in a well-ventilated drying oven maintained at a temperature between 35°C and 40°C and test dry.

4.2 Anhydrous Gypsum Plaster and Keene's Plaster — Prepare four test specimens as follows:

- a) A convenient quantity of plaster to use is 400 g. Add this over a period of 30 seconds to the appropriate amount of water to produce a standard final coat consistence. Stir the mix with a stiff-bladed spatula for 30 seconds in the case of anhydrous gypsum plaster and for 60 seconds in case of Keene's plaster.
- b) Determine the precise quantity of water needed by a previous trial as described in **4.3**.
- c) Fill the moulds in two layers, tamping each layer ten times with a 6 mm² brass rod along the length of the mould. Strike off the surface level with the top of the mould.
- d) Ensure that the specimens remain undisturbed in the moulds for 24 hours under a damp cloth or in a damp closet and then remove them from the moulds. Store them in a damp closet for three days. Finally, dry them to constant weight in a well-ventilated drying oven maintained at a temperature between 35°C and 40°C and test dry.

4.3 Standard Consistency — Determine the standard final coat consistency by means of a dropping ball penetrometer precisely as described in **3.3.2.1** of Part I/Section 4, except that the correct consistency in the present test corresponds to a penetration of 15-16 mm.

When early stiffening occurs, 0.1 g of sodium citrate may be added to the gauging water for the determination of consistency.

5. PROCEDURE

5.1 Determine the resistance of the plaster to the impact of a falling ball by measuring the diameter of the impression produced on the smooth surface (which was in contact with the internal face of the mould when casting) of four neat plaster rods 25 mm^2 in cross section and 100 mm long, prepared, stored and dried as described in 4, when the hard steel ball is allowed to fall freely from rest from a height of 1.82 m on to the horizontal surface of the plaster.

5.2 After cleaning and polishing the hard steel ball, release it from rest down a straight, smooth, clean and dry tube approximately 16 mm in internal diameter and 1.72 m in length, supported firmly in a vertical position with the top of the specimen 100 mm below the bottom of the tube. Support the specimen under test firmly on a smooth, substantial and unyielding horizontal surface.

5.3 Make eight impressions in all, one on each of the opposite faces of the four rods, avoiding blemishes and air-bubbles, and not more than 6 mm from the centre line or within 12 mm of the ends of the rod, measuring two diameters at right angles for each impression. Neglect any impression obviously irregular in shape and repeat the test on that face. Record the mean of the sixteen measurements.

As in the Original Standard, this Page is Intentionally Left Blank

Indian Standard

METHODS OF TEST FOR GYPSUM
PLASTER, CONCRETE AND PRODUCTS

PART I PLASTER AND CONCRETE

Section 8 Freedom from Coarse Particles

(*First Revision*)

(Incorporating Amendment No. 1)

1. SCOPE

1.1 This standard (Part I/Sec 8) covers the procedure for determining the extent to which the plaster is free from coarse particles.

2. TERMINOLOGY

2.1 For the purpose of this standard, the definitions given in IS : 2469-1976* shall apply.

3. PROCEDURE

3.1 Sift 100 g of plaster continuously for 5 minutes on a 1.18 mm or 90 µm IS Sieve, as required, and the residue on the sieve weighed and reported.

3.1.1 Air-set lumps in the sample may be broken down with the fingers, but nothing shall be rubbed on sieve.

*Glossary of terms relating to gypsum (*first revision*).

As in the Original Standard, this Page is Intentionally Left Blank

Indian Standard

METHODS OF TEST FOR GYPSUM PLASTER, CONCRETE AND PRODUCTS

PART I PLASTER AND CONCRETE

Section 9 Expansion of Plaster

(First Revision)

1. SCOPE

1.1 This standard (Part I/Sec 9) covers the procedure for determining the linear expansion of neat plaster gauged to a standard stiff consistency on setting in continuous damp air storage by means of a simple extensometer.

2. TERMINOLOGY

2.1 For the purpose of this standard, the definitions given in IS : 2469-1976* shall apply.

3. APPARATUS

3.1 Extensometer — The extensometer has an open V-shaped cradle closed at one end by a fixed plate, and at the other end by a movable partition carried on the stem of an ordinary watch pattern dial micrometer gauge, reading to 0.01 mm (*see* Fig. 1). The cradle of brass or bronze is 100 mm long, about 60 mm wide and 25 mm deep, with a rounded bottom. The take up or the returning spring shall be light, and the movement free.

3.1.1 To prevent the plaster sticking to the sides of the cradles it shall be greased before use and lined internally with thin non-absorbent paper having a glazed surface. The paper lining shall be renewed after each test.

4. PROCEDURE

4.1 The stiff paste of the plaster is filled into the cradle whilst the movable plate is held against the end and struck off smooth and level with the top of the cradle.

*Glossary of terms relating to gypsum (*first revision*).

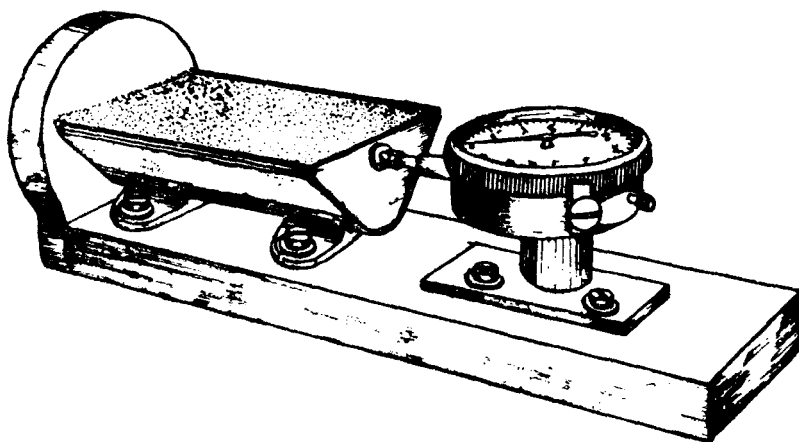

FIG. 1 EXTENSOMETER

4.1.1 Zero Adjustment — The movable partition is very slightly moved forward clear of the end to eliminate backlash. The plaster is brought solid against the movable partition. The necessary zero adjustment on the dial, if any, is then made.

4.1.2 A convenient quantity of plaster to use is about 200 g. This is gauged with water in the manner and to the same stiff consistency as described in **4.3** of Section 7 and the mixed plaster is filled immediately into the cradle of the extensometer and the zero point adjusted as described in **4.1.1**.

4.1.3 The instrument is then maintained at a relative humidity of at least 80 percent and at a temperature of $27 \pm 2^\circ\text{C}$ and the zero reading noted. It is left undisturbed until the final reading is taken at the end of 24 hours.

5. REPORT

5.1 The percentage linear expansion is then calculated and reported as follows:

$$\text{Linear expansion} = \frac{\text{Difference in dial reading in } 1/100 \text{ mm}}{100}$$

Indian Standard

METHODS OF TEST FOR GYPSUM PLASTER, CONCRETE AND PRODUCTS

PART I PLASTER AND CONCRETE

Section 10 Sand in Set Plaster

(First Revision)

1. SCOPE

1.1 This standard (Part I/Sec 10) covers the procedure for determining sand in set plaster by ammonium acetate method.

2. TERMINOLOGY

2.1 For the purpose of this standard, the definitions given in IS : 2469-1976* shall apply.

3. GENERAL

3.1 For accurate results the following determinations shall be made for the determination of the sand content in set gypsum plaster:

- a) Determination of the percentage of insoluble matter in the sand used with the plaster,
- b) Determination of the percentage of insoluble matter in the gypsum neat plaster, and
- c) Determination of the percentage of insoluble matter in the sanded calcined plaster.

NOTE — If samples of the original gypsum neat plaster and the sand are not available, an approximation of the insoluble matter may be obtained by use of this method on plaster and sand from the same sources as those from which the plaster to be analysed was originally prepared.

4. SAMPLING

4.1 Where plaster to be tested is part of a two-coat or three-coat plastering operation, the sample for analysis shall be taken from that portion of the entire plaster sheet which comprises the single coat being tested. Succeeding coats of plaster shall be separated by use of a stiff putty knife or similar implement. At least 500 g shall be taken as a sample, the sample preferably being obtained from different sections of the wall or ceiling under examination.

*Glossary of terms relating to gypsum (*first revision*).

5. PROCEDURE

5.1 In a clean porcelain mortar, grind the set plaster sample to the size of the largest sand particles present, or smaller, so that approximately 100 percent of the sample will pass a 2.36-mm IS sieve. Fine grinding makes solution of the gypsum faster. Place about 200 g of the ground sample in a porcelain casserole or evaporating dish, and calcine on a sand bath. Stir the sample continuously with a thermometer during beating, and adjust the rate of heating so that 20 to 30 minutes will be required to raise the temperature of the sample to $160 \pm 5^\circ\text{C}$. Cool the sample to room temperature.

5.2 After cooling, weigh accurately 20 ± 0.05 g of the calcined sample into a 600-ml beaker. Add 300 ml of ammonium acetate (25 percent), which should be slightly alkaline to litmus paper. If acidic, add a few millilitres of ammonium hydroxide (1 : 59) to the stock solution of ammonium acetate to render it slightly alkaline prior to the addition to the test sample.

5.3 Warm the suspension to a temperature of $70 \pm 5^\circ\text{C}$ and stir continuously for 20 to 30 minutes. Filter the warm suspension with the aid of suction through a small Buchner funnel or Gooch crucible in which an asbestos mat or filter paper has previously been formed, the funnel and mat having been dried at 110°C to constant weight within 0.01 g. Refilter the first 100 ml of the filtrate. Wash the sand remaining in the beaker on to the filter with an additional 100 ml of warm ammonium acetate solution. Wash the beaker and residue with 200 to 300 ml of water, dry the funnel and sand at 100°C to constant weight. The weight of the residue is the weight of insoluble matter.

5.4 Percentage of Insoluble Matter in Plaster — Multiply the weight of the insoluble matter obtained in **5.3** by 5 to obtain the percentage of insoluble matter in the sanded plaster.

5.5 Percentage of Insoluble Matter in Sand — Determine the weight of insoluble matter in the sand as described in **5.1** to **5.3**, except that no grinding of the sample is necessary. Multiply the weight of the insoluble matter obtained by 5 to obtain the percentage of insoluble matter in the sand.

5.6 Percentage of Insoluble Matter in Gypsum Neat Plaster — Determine the weight of insoluble matter in the gypsum neat plaster as described in **5.1**, to **5.3**, except that only a 5 g sample is required and no grinding of the sample is necessary. Multiply the weight of the insoluble matter obtained by 20 to obtain the percentage of insoluble matter in the gypsum neat plaster.

6. CALCULATION

6.1 Calculate and report the percentage of sand in the sanded plaster as follows:

$$X = \frac{(C - B) 100}{(A - B)}$$

where

X = percentage of sand in sanded plaster,

C = percentage of insoluble matter in the sanded plaster,

B = percentage of insoluble matter in the gypsum neat plaster,
and

A = percentage of insoluble matter in the sand.

6.2 To express the results as a ratio of the parts of sand per part of plaster by weight, the following formula may be used:

$$\text{Ratio of sand to plaster} = \frac{X}{(100 - X)}$$

where

X = percentage of sand in sanded plaster (*see 6.1*).

NOTE — The results obtained by the above procedure indicate the amount of sand originally mixed with the gypsum neat plaster before it had been gauged with water or set.

As in the Original Standard, this Page is Intentionally Left Blank

Indian Standard

METHODS OF TEST FOR GYPSUM PLASTER, CONCRETE AND PRODUCTS

PART I PLASTER AND CONCRETE

Section 11 Wood Fibre Content in Wood Fibre Gypsum Plaster

(First Revision)

1. SCOPE

1.1 This standard (Part I/Sec 11) covers the procedure for determining wood fibre content in wood fibre plaster.

2. TERMINOLOGY

2.1 For the purpose of this standard, the definitions given in IS : 2469-1976* shall apply.

3. PREPARATION OF SAMPLE

3.1 Weigh a sample of not less than 0.5 kg of the material as received and spread it out in thin layer in a suitable vessel. Place in an oven and dry at 45°C for 2 hours, then cool in an atmosphere free from moisture. Reduce the sample to pass a 250-micron IS Sieve, taking extreme care not to expose unduly the material to moisture or to overheating. Thoroughly remix the ground sample, and store it in an air-tight container until used.

4. PROCEDURE

4.1 Place a 100 g sample of wood fibre plaster prepared as described in **3** on a 600-micron IS Sieve nested over a 150-micron IS Sieve. Wash the plaster on the 600-micron IS Sieve with a stream of cold water, removing the 600-micron IS Sieve when the fibre on it is practically or entirely free of plaster. Next, wash the material on the 150-micron IS Sieve until the bulk of the plaster has been washed through the sieve and the residue is mainly fibre. Transfer the material retained on the 150-micron IS Sieve to a 4-litre vitreous enamel lipped pan, adding the charge on the 600-micron IS Sieve if the fibre contains any adhering particles of plaster. Elutriate the material in the pan (purify by

*Glossary of terms relating to gypsum (*first revision*).

IS : 2542 (Part I/Sec 11) - 1978

washing and straining, effecting as clear a separation of fibre from plaster as is feasible), catching the elutriated fibres on a 150-micron IS Sieve. To avoid loss of the fine particles of fibre, it may be necessary to make the transfer from the pan to the 150-micron IS Sieve by several stages of washing, stirring the charge and quickly pouring upon the sieve the fibre floatations, repeating the elutriation procedure several times. Examine the fibre collected on the 150-micron IS Sieve and repeat the elutriation if it seems desirable.

4.2 Dry the sieves (or sieve, as the case may be) and the residue contained therein in an oven maintained at a temperature of 45°C. Carefully invert the sieves over a piece of white paper, and transfer the residual material to the paper by brushing the bottom of the inverted sieve. Examine the transferred material visually, noting whether the separation of fibres from plaster has been completed. Then transfer the material to a weighed platinum crucible and dry to constant weight at a temperature of 45°C.

5. REPORT

5.1 If visual examination of the charge on the white paper showed that the fibre was practically free of particles of plaster, report as the percentage of fibre the mass of the fibre dried at 45°C, divided by 100. If, on the other hand, the visual examination revealed the presence of an appreciable quantity of plaster associated with the fibre, carefully ignite the contents of the crucible to constant mass. In this case, report as the percentage of fibre the loss on ignition, divided by 100.

Indian Standard

METHODS OF TEST FOR GYPSUM PLASTER, CONCRETE AND PRODUCTS

PART I PLASTER AND CONCRETE

Section 12 Dry Bulk Density

(First Revision)

1. SCOPE

1.1 This standard (Part I/Sec 12) covers the procedure for determining the dry bulk density of gypsum plaster.

2. TERMINOLOGY

2.1 For the purpose of this standard, the definitions given in IS : 2469-1976* shall apply.

3. PROCEDURE

3.1 Pour the plaster sample directly into a cube container of volume 0.02 m^3 (the internal length of the side of the cube container is 271.5 mm) from a height not exceeding 50 mm above the top of the container and strike off the extraneous material flat with the top of the cube. Do not tamp or use any other compaction. Weigh the quantity of plaster to an accuracy of $\pm 50 \text{ g}$ (W).

4. CALCULATION

4.1 Determine the bulk density of the plaster sample in kg/m^3 from the following equation:

$$\text{Bulk density} = W \times 50$$

*Glossary of terms relating to gypsum (*first revision*).

Bureau of Indian Standards

BIS is a statutory institution established under the *Bureau of Indian Standards Act, 1986* to promote harmonious development of the activities of standardization, marking and quality certification of goods and attending to connected matters in the country.

Copyright

BIS has the copyright of all its publications. No part of these publications may be reproduced in any form without the prior permission in writing of BIS. This does not preclude the free use, in the course of implementing the standard, of necessary details, such as symbols and sizes, type or grade designations. Enquiries relating to copyright be addressed to the Director (Publications), BIS.

Review of Indian Standards

Amendments are issued to standards as the need arises on the basis of comments. Standards are also reviewed periodically; a standard along with amendments is reaffirmed when such review indicates that no changes are needed; if the review indicates that changes are needed, it is taken up for revision. Users of Indian Standards should ascertain that they are in possession of the latest amendments or edition by referring to the latest issue of 'BIS Catalogue' and 'Standards : Monthly Additions'.

This Indian Standard has been developed by Technical Committee : BDC 21 and amended by CED 21

Amendments Issued Since Publication

Part/Sec No.	Amend No.	Date of Issue
Part 1/Sec 8	Amd. No. 1	September 1991

BUREAU OF INDIAN STANDARDS

Headquarters:

Manak Bhavan, 9 Bahadur Shah Zafar Marg, New Delhi 110002.
Telephones: 323 01 31, 323 33 75, 323 94 02

Telegrams: Manaksanstha
(Common to all offices)

Regional Offices:

	Telephone
Central : Manak Bhavan, 9 Bahadur Shah Zafar Marg NEW DELHI 110002	{ 323 76 17 323 38 41
Eastern : 1/14 C. I. T. Scheme VII M, V. I. P. Road, Kankurgachi KOLKATA 700054	{ 337 84 99, 337 85 61 337 86 26, 337 91 20
Northern : SCO 335-336, Sector 34-A, CHANDIGARH 160022	{ 60 38 43 60 20 25
Southern : C. I. T. Campus, IV Cross Road, CHENNAI 600113	{ 235 02 16, 235 04 42 235 15 19, 235 23 15
Western : Manakalaya, E9 MIDC, Marol, Andheri (East) MUMBAI 400093	{ 832 92 95, 832 78 58 832 78 91, 832 78 92

Branches : AHMEDABAD. BANGALORE. BHOPAL. BHUBANESHWAR. COIMBATORE.
FARIDABAD. GHAZIABAD. GUWAHATI. HYDERABAD. JAIPUR. KANPUR. LUCKNOW.
NAGPUR. NALAGARH. PATNA. PUNE. RAJKOT. THIRUVANANTHAPURAM.
VISHAKHAPATNAM