

इंटरनेट

मानक

Disclosure to Promote the Right To Information

Whereas the Parliament of India has set out to provide a practical regime of right to information for citizens to secure access to information under the control of public authorities, in order to promote transparency and accountability in the working of every public authority, and whereas the attached publication of the Bureau of Indian Standards is of particular interest to the public, particularly disadvantaged communities and those engaged in the pursuit of education and knowledge, the attached public safety standard is made available to promote the timely dissemination of this information in an accurate manner to the public.

“जानने का अधिकार, जीने का अधिकार”

Mazdoor Kisan Shakti Sangathan

“The Right to Information, The Right to Live”

“पुराने को छोड़ नये के तरफ”

Jawaharlal Nehru

“Step Out From the Old to the New”

IS 2696 (1974): Functional Requirements for 1 125-1/min
Light Fire Engine [CED 22: Fire Fighting]



“ज्ञान से एक नये भारत का निर्माण”

Satyanarayan Gangaram Pitroda

“Invent a New India Using Knowledge”



“ज्ञान एक ऐसा खजाना है जो कभी चुराया नहीं जा सकता है”

Bhartrhari—Nitiśatakam

“Knowledge is such a treasure which cannot be stolen”

BLANK PAGE



IS : 2696 - 1974
(Reaffirmed 2007)

Indian Standard
FUNCTIONAL REQUIREMENTS FOR
1 125-I/min LIGHT FIRE ENGINE
(First Revision)

Third Reprint JUNE 1996

UDC 614.846.6

© Copyright 1974

BUREAU OF INDIAN STANDARDS
MANAK BHAVAN, 9 BAHADUR SHAH ZAFAR MARG
NEW DELHI 110002

Gr 4

November 1974

Indian Standard

**FUNCTIONAL REQUIREMENTS FOR
1 125-l/min LIGHT FIRE ENGINE**

(First Revision)

Fire Fighting Sectional Committee, BDC 22

<i>Chairman</i>	<i>Representing</i>
SHRI P. N. MEHROTRA	Ministry of Home Affairs
<i>Members</i>	
SHRI G. B. MENON (<i>Alternate to</i> Shri P. N. Mehrotra)	Central Building Research Institute (CSIR), Roorkee
DR G. N. BADAMI	Central Building Research Institute (CSIR), Roorkee
SHRI GOPAL KRISHAN (<i>Alternate</i>)	Insurance Association of India, Bombay
SHRI P. K. BHARUCHA	Insurance Association of India, Bombay
SHRI A. CHATTERJI (<i>Alternate</i>)	Air Foam Industries, New Delhi
SHRI M. B. CHAKANKAR	Air Foam Industries, New Delhi
SHRI R. MEHTA (<i>Alternate</i>)	West Bengal Fire Services, Calcutta
SHRI S. C. CHATTERJEE	National Safety Council, Bombay
BRIG P. R. CHAUHAN	National Safety Council, Bombay
SHRI R. R. DHOBLEY	Bhaba Atomic Research Centre, Trombay, Bombay
DIRECTOR, FIRE SERVICE	Home (Police) Department, Government of Andhra Pradesh
SHRI P. N. GHOSH	Ministry of Defence (R & D)
SHRI A. N. AHLUWALIA (<i>Alternate</i>)	Ministry of Defence (R & D)
DR D. S. JAISWAR	Avon Services (Production & Agencies) Private Limited, New Delhi
SHRI A. S. KULKARNI	Bombay Fire Brigade, Bombay
SHRI D. K. MAJUMDER	Allen Richards & Co, Calcutta
SHRI A. K. MITRA (<i>Alternate</i>)	Allen Richards & Co, Calcutta
SHRI D. M. B. MAJUMDER	Minimax Ltd, Calcutta
SHRI S. C. DUTTA (<i>Alternate</i>)	Minimax Ltd, Calcutta
SHRI S. P. NAG	Ministry of Railways
SHRI R. NITYANANDAM	Fire Service, Government of Tamil Nadu, Madras
SHRI N. DEVARAJAN (<i>Alternate</i>)	Fire Service, Government of Tamil Nadu, Madras
SHRI H. C. RAI CHOUDHURY	Directorate General of Civil Aviation (Ministry of Tourism & Civil Aviation)
LT-COL B. N. S. RAO	Ministry of Defence (DGI)
MAJ B. B. RAJPAL (<i>Alternate</i>)	Ministry of Defence (DGI)

(Continued on page 2)

© Copyright 1974

BUREAU OF INDIAN STANDARDS

This publication is protected under the *Indian Copyright Act* (XIV of 1957) and reproduction in whole or in part by any means except with written permission of the publisher shall be deemed to be an infringement of copyright under the said Act.

IS : 2696 - 1974

(Continued from page 1)

<i>Members</i>	<i>Representing</i>
SHRI K. RAMAKRISHNA RAO	Directorate General of Technical Development (Ministry of Industrial Development)
SHRI P. L. SEBASTIN	Oil & Natural Gas Commission, Dehra Dun
SHRI V. V. KIMMATKAR (<i>Alternate</i>)	
SHRI G. C. SENAPATI	Hindustan Steel Limited, Ranchi
SHRI P. CHATTERJEE (<i>Alternate</i>)	
SHRI P. H. SETHNA	Kooverji Devshi & Co (P) Ltd, Bombay
SHRI N. T. PANJWANI (<i>Alternate</i>)	
SHRI J. V. SHAH	Newage Industries, Surendranagar
SHRI M. K. SHAH (<i>Alternate</i>)	
SHRI V. N. SHARMA	DGL Private Limited, New Delhi
SHRI F. E. BRAIN (<i>Alternate</i>)	
SHRI C. R. SIRCAR	Directorate General of Supplies & Disposals (Ministry of Supply)
SHRI D. K. SIRKAR	Synthetics & Chemicals Ltd, Bareilly
SHRI R. S. SUNDARAM	Municipal Corporation of Delhi (Delhi Fire Service)
SHRI N. P. VERGHESI	Heavy Engineering Corporation Ltd, Ranchi
SHRI B. V. WAGLE	Directorate of Civil Defence (Operation), Govern- ment of Maharashtra, Bombay
SHRI R. R. RAO (<i>Alternate</i>)	
SHRI D. AJITHA SIMHA, Director (Civ Engg)	Director General, BIS (<i>Ex-officio Member</i>)

Secretary

SHRI K. M. MATHUR
Deputy Director (Civ Engg), BIS

Fire Fighting Units Subcommittee, BDC 22 : 3

Convener

SHRI P. N. GHOSH Ministry of Defence (R & D)

Members

SHRI A. N. AHLUWALIA (<i>Alternate</i> to Shri P. N. Ghosh)	
SHRI F. E. BRAIN	DGL Private Limited, New Delhi
SHRI V. N. SHARMA (<i>Alternate</i>)	
SHRI S. C. CHATTERJEE	West Bengal Fire Services, Calcutta
SHRI M. L. DHIR	Ministry of Defence (DGI)
SHRI L. R. SUD (<i>Alternate</i>)	
SHRI A. S. KULKARNI	Bombay Fire Brigade, Bombay
SHRI P. N. MEHROTRA	Ministry of Home Affairs
SHRI G. B. MENON (<i>Alternate</i>)	
SHRI V. N. MEHTA	Mahindra & Mahindra Ltd, Bombay
SHRI A. S. NAGARAJ (<i>Alternate</i>)	
WO CDR P. PAPPU	Air Headquarters (Ministry of Defence)
SHRI R. B. MOHINDRA (<i>Alternate</i>)	

(Continued on page 15)

AMENDMENT NO. 1 OCTOBER 1975
TO
IS : 2696-1974 FUNCTIONAL REQUIREMENTS FOR
1 125-l/min LIGHT FIRE ENGINE
(First Revision)

Alterations

(Page 5, clause 4.2.3, line 1) — Substitute 'indirect cooling' for 'radiator'.

(Page 7, clause 4.4.1)

a) Delete the words 'either 6- or'.

b) Substitute 'IS : 7372-1974*' for 'IS : 985-1962*'.

(Page 7, foot-note) — Substitute the following for the existing foot-note:

'*Specification for lead-acid storage batteries for motor vehicles.'

[Page 8, clause 4.7.1 (b)] — Substitute '16 kgf/cm²' for '17.5 kg/cm²'.

[Page 8, clause 4.7.1 (c)] — Substitute '0 to 5 kgf/cm²' for '0 to 6 kg/cm²'.

(Page 9, clause 4.8.1, sentences 2 and 3) — Substitute the following sentence for the second and third sentences:

'The body work shall be of open type.'

(Page 13, Appendix A, Sl No. 4) — Substitute '75-mm' for '100-mm'

AMENDMENT NO. 2 APRIL 1977

TO

IS:2696-1974 FUNCTIONAL REQUIREMENTS
FOR 1125-1/min LIGHT FIRE ENGINE

(First Revision)

Alteration

[Page 7, clause 4.5.2(a)] - Substitute
'2.5°C' for '2.8°C'.

(BDC 22)

Printed at Simco Printing Press, Delhi, India

Indian Standard

FUNCTIONAL REQUIREMENTS FOR 1 125-l/min LIGHT FIRE ENGINE

(First Revision)

0. FOREWORD

0.1 This Indian Standard (First Revision) was adopted by the Indian Standards Institution on 15 March 1974, after the draft finalized by the Fire Fighting Sectional Committee had been approved by the Civil Engineering Division Council.

0.2 This standard was published in 1964. Since the issue of the standard considerable experience has been gained with regard to the actual working to the standard and certain difficulties in regard to chassis have come to light. The sectional committee has taken note of this experience and has issued this revision in which some of the requirements have been amended suitably in light of indigenously produced chassis suitable for making up fire engine.

0.3 For the purpose of deciding whether a particular requirement of this standard is complied with, the final value, observed or calculated, expressing the result of a test or analysis, shall be rounded off in accordance with IS : 2-1960*. The number of significant places retained in the rounded off value should be the same as that of the specified value in this standard.

1. SCOPE

1.1 This standard lays down the requirements regarding material, design, construction, workmanship and finish, accessories, equipment, and acceptance tests for 1 125-l/min light fire engine.

2. GENERAL REQUIREMENTS

2.1 The appliance shall consist of a very light transport vehicle capable of traversing rough and hilly terrains as would be encountered in rural and hilly areas and shall be capable of being easily manoeuvred in the very narrow streets of towns and congested areas of cities. It shall have either a front-mounted pump or a rear-mounted pump as required.

*Rules for rounding off numerical values (*revised*).

IS : 2696 - 1974

2.2 The appliance when fully laden (but without trailer) shall be able to attain a maximum road speed of 65 km/h on a level road. The acceleration shall be such that with a warm running engine, the fully laden appliance shall attain a speed of 55 km/h from a standing start through gears in a maximum time of 40 seconds. The appliance shall also be capable of being started from rest up a gradient of 1 in 4 when fully laden. When a trailer is attached with the appliance the speed of the appliance should not exceed 30 km/h.

2.3 Brakes shall be fitted on all the four wheels and shall be on hydraulic system (preferably of vacuum or air-assisted type). These shall be capable of stopping the vehicle when travelling at 45 km/h (fully-laden and manned on dry road) within a distance of 6 m from the point at which the brake is applied. The hand brake system shall be capable of holding the fully-laden appliance stationary on a dry surface gradient 1 in 4 when in neutral gear.

2.4 The design and construction of all parts shall be such that it is possible to supply replaceable parts and that they will fit in correctly.

3. MATERIAL, SELECTION AND TREATMENT

3.1 The choice of material to be used in the construction of the appliance shall be made with a view to combining lightness with strength and durability.

3.2 All parts which form waterways or come in contact with water shall be of corrosion-resisting material. All metal parts exposed to atmosphere shall either be corrosion-resistant or shall be treated suitably.

4. DESIGN AND CONSTRUCTION

4.1 Chassis

4.1.1 The chassis shall be designed for carrying a load which exceeds the estimated maximum load (including loose equipment detailed in Appendix A and a crew of four men). The total weight of the appliance, when fully-laden, shall not exceed the rated gross vehicle weight (GVW) of the vehicle. It shall be taken into account that the appliance stands laden throughout most of its life. The wheel base shall be between 2.0 m and 2.2 m and the overall width shall not exceed 1.9 m. The turning circle shall be as small as possible, but not more than 12 m. The ground clearance shall be not less than 20 cm.

4.1.2 The chassis shall be a four-wheeler with drive on all the four wheels. The tyre size and treads shall be such as to ensure easy floatation and traction on soft soil and rough and hilly terrain. The appliance shall be capable of good cross-country performance. The appliance shall be

fitted with stabilizer, if possible. Drag hooks or eyes of adequate strength shall be fitted to all chassis members at front and rear. The lubricating nipples shall be located at accessible and protected positions. Where nipples are fitted on or adjacent to their bearings and are connected to them by pipes, plates on the nipples shall be provided to indicate the points which they serve. The springs shall be of high grade steel, preferably of elliptical type and shall incorporate anti-roll leaves, if possible. Shock absorbers shall be fitted to all the wheels. Provision shall be made at the rear for a towing hitch (*see Fig. 1*) suitable for a two-wheeled trailer. The driving position shall preferably be forward or semi-forward.

4.1.3 Gear-box shall have at least three speeds. Provision shall be made for working the pump direct from the transmission. Means shall be provided to determine reasonably accurately the oil level in the gear-box, preferably by a dip-stick, if possible.

4.2 Engine

4.2.1 The engine shall be petrol driven and shall be capable of developing not less than 33.5 kW at 4 000 rev/min and a torque of 15.7 kg at 2 000 rev/min. Means shall be provided to ensure reliable and quick starting up of the engine and, in addition to an electrically-operated starter of adequate power, a well-designed hand-starting device may also be provided.

4.2.2 The engine shall be capable of driving the fully-laden appliance at speed from starting-up without any preliminary running period, even under cold atmospheric conditions using immersion heaters in the oil and water circuits, where necessary, to enable this requirement to be fulfilled. Any immersion heater in the oil-sump shall not be of such a type or capacity as to cause carbonization. The operating temperature of the engine-cooling water shall preferably be thermostatically-controlled.

4.2.3 Heat exchanger of radiator system shall be provided to permit prolonged running of the pump without overheating. This shall be of open-circuit type to permit discharge of water to waste. Control valve shall be provided to regulate water supply in the indirect cooling system. Heat exchanger shall be so selected that operating temperature does not exceed the value specified under 7.1(c).

4.2.4 Suitable temperature indicating gauge for water, and oil pressure indicating gauge for lubricating system appropriately marked with their normal operating ratings shall be provided on the instrument panel in the driver's enclosure. The engine lubricating system shall be provided with an accessible external filter. Means shall be provided to gauge reasonably accurately, with the engine stopped, the level of the oil in the sump, preferably by a tubed dip-stick.

4.2.5 Clutch shall be of heavy-duty type.

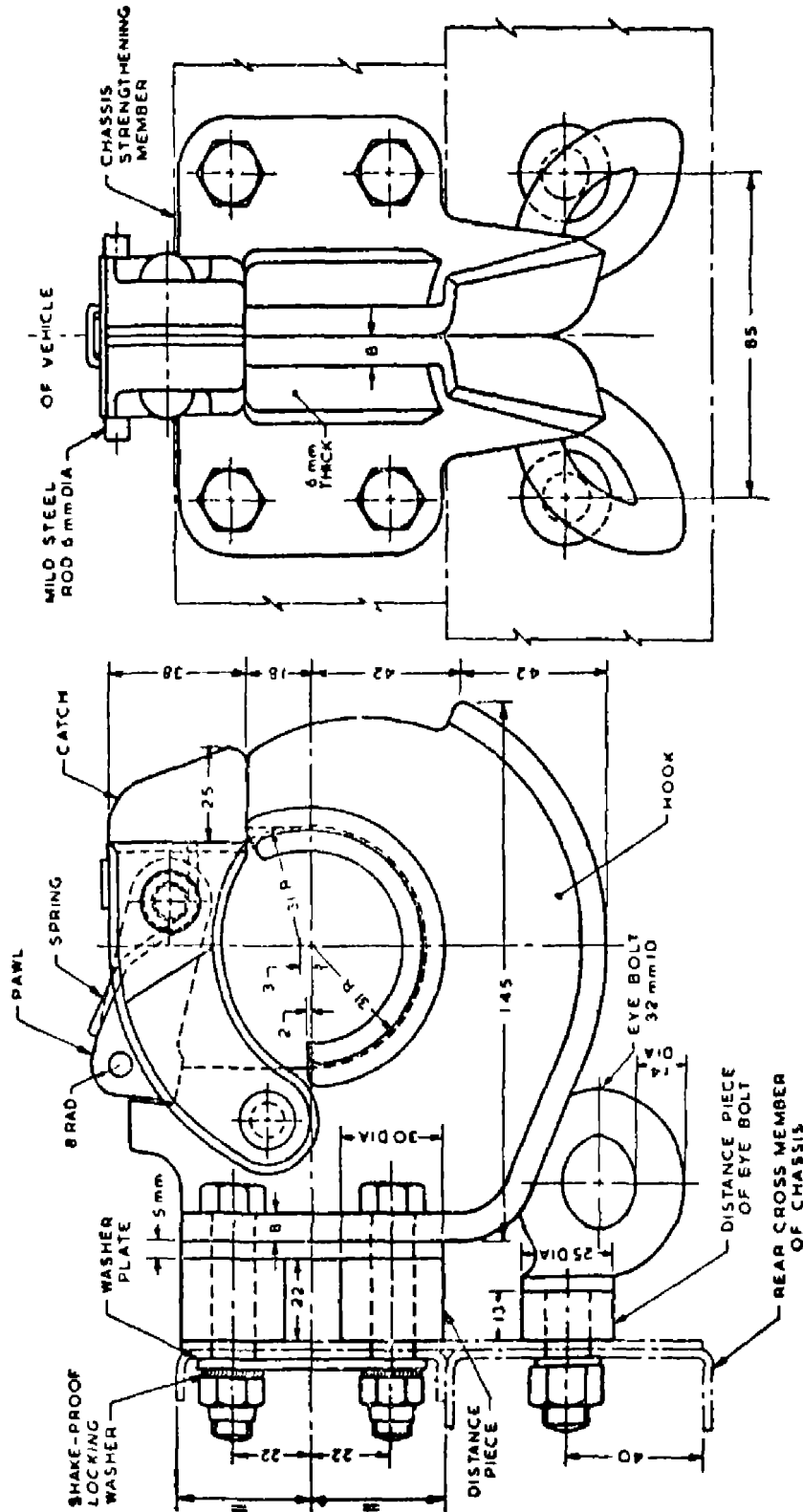

All dimensions in millimetres.
 FIG. 1 TOWING HITCH

4.3 Fuel System

4.3.1 The fuel tank shall have a capacity of not less than 60 litres. A fuel tank content gauge shall be fitted on the instrument panel in the driver's enclosure.

4.3.2 The filling orifice shall be of ample size (not less than 50 mm) and shall be in an accessible position. The cap shall be clearly marked to show that it is for fuel, and an anti-flash device shall be incorporated in it.

4.3.3 There shall be two fuel pumps, one of which shall be mechanically-operated and shall preferably be provided with a hand-operated device.

4.4 Electrical Equipment

4.4.1 The electrical system may be either 6- or 12-volt. In either case the batteries shall conform to IS : 985-1962*.

4.4.2 The dynamo/alternator shall be of the heavy-duty type.

4.4.3 Separate fuses shall be provided for all important electrical circuits. These shall be suitably indicated and grouped into a common fuse-box which shall be located in an accessible position. The fuse-box shall have provision for carrying spare fuses in it.

4.5 Pump

4.5.1 The pump shall be of centrifugal type and so designed as to afford easy access to the impeller. It shall preferably be of single stage design and shall be as light as possible. The pump shaft shall be made of stainless steel and shall be carried in anti-friction bearings within the casing in the case of front-mounted pump and external of the casing in the case of rear-mounted pump. The impeller neck ring and the impeller rings shall be renewable and manufactured from high quality bronze. The glands shall preferably be of self-adjusting type. A drain plug shall be provided at the bottom of the casing.

4.5.2 The pump shall be tested for its performance duties (*see 4.5.3*) at 16.5°C and at atmospheric pressure of 760 mm of mercury. The following allowances shall be made:

- a) One percent for every 2.8°C temperature-rise;
- b) Four percent for every 300 m elevation above mean sea level; and
- c) No allowance shall be made for humidity up to 75 percent. However, suitable deductions shall be made when the humidity ranges from 75 to 95 percent.

NOTE — Suction lift is reduced by 30 cm for every 300 m elevation above mean sea level. The temperature of water also affects the lift and output, and necessary variation may be allowed.

*Specification for lead-acid storage batteries (heavy duty) for motor vehicles (*revised*).

4.5.3 The pump, when tested (see 4.5.2), shall be capable of fulfilling the duties given in Table 1.

TABLE 1 DUTIES OF THE PUMP

Sl No.	OUTPUT NOT LESS THAN	DISCHARGE PRESSURE	LIFT MEASURED VERTICALLY FROM WATER LEVEL TO SUCTION EYE	CONDITION
(1)	(2)	(3)	(4)	(5)
	l/min	kg/cm ²	m	
i)	1 125	7.0	3	Working through 5 m, that is, two 2.5-m lengths of specified suction hose
ii)	1 100	8.5	3	Working through 10 m, that is, four 2.5-m lengths of specified suction hose

4.5.4 Suction inlet shall be provided with a standard 75-mm suction hose connection with removable internal strainer and blank cap. The strainer, although readily removable, shall be retained firmly in position when in use. There shall be two delivery valves having 63 mm quick release couplings with quick closing valves and standard hose connections. Blank caps shall be provided and there shall be arrangements for relieving pressure between the valve and the cap.

4.5.5 The pump shall be mounted either at the front or at the rear of the appliance.

4.6 **Primer** — The primer shall be capable of lifting water at least through 7.0 m at a rate of not less than 30 cm/s and shall preferably be fully automatic thus eliminating the need for any action on the part of the pump operator. If the primer is of the reciprocating piston type and is subject to speed limitation; then means shall be provided to limit automatically the speed of the engine while the primer is engaged.

4.7 Control Panel

4.7.1 Adequately illuminated control panel shall be provided and positioned according to the position of the pump and shall include the following items:

- a) Throttle control for the engine;
- b) Pressure gauge calibrated from 0 to 17.5 kg/cm²;
- c) Compound gauge calibrated as follows:
 - Vacuum — 0 to 750 mm of mercury in red, and
 - Pressure — 0 to 6 kg/cm² in black;

- d) Primer control, if the primer is not fully automatic; and
- e) Revolution indicator, if available.

4.7.2 The pipes connecting the gauges shall be designed for self drainage. Each gauge pipe shall be fitted with a cock.

4.7.3 The control panel shall be adjacent to the suction and delivery connections.

4.8 Bodywork and Stowage

4.8.1 The body shall provide seating accommodation for two men including driver in the front and standing accommodation at the rear on the footboard with grab rails for two men. The body work shall be designed so as to enclose as much as possible of the appliance without interfering with necessary accessibility but at the same time the body shall have clean lines. If windows are provided, they shall have safety glasses. The driver's seat shall be adjustable. Provision shall be made for carrying a 4.5-m extension ladder on the appliance.

4.8.2 Lockers or other suitable accommodation shall be provided for all the equipment detailed in Appendix A. A spare wheel with tyre and tube shall be supplied with the appliance but no provision for mounting the wheel on the vehicle is required. However, a carrier for carriage of the spare wheel during road transportation shall be provided.

4.8.3 All lockers shall have internal lighting, preferably automatically switched 'on' and 'off' by the opening and closing of the doors or lids. A master switch for insulation of the locker-lighting circuit shall be fitted in the driving compartment.

4.8.4 If required, provision for wireless equipment to suit requirements shall be made, the control panel of the wireless equipment shall be located in the driver's enclosure. A long arm outside fitting type rear view mirror may also be provided.

4.8.5 Grab rails and non-skid steps to assist the crew to mount and dismount shall be provided at the back of the vehicle where required.

4.8.6 No part of the bodywork shall reduce the road clearance to less than 20 cm, when the appliance is fully loaded nor increase the width of the appliance to more than 2.0 m. The highest part of the appliance with extension ladder mounted shall not exceed 2.5 m from ground level.

4.8.7 All seats shall be filled with sponge rubber and covered with PVC coated leather cloth.

IS : 2696 - 1974

4.8.8 Compartments and lockers provided for the stowage of equipment shall be fitted with readily accessible quick release brackets and hanging racks. Racks shall be preferably painted as shadow boards for ready identification of each equipment. All lockers shall be dustproof with hinged doors and recessed handles.

4.8.9 Doors of lockers shall have efficient means of holding them open and efficient flush-fitting spring-loaded locks. Doors of side lockers with the exception of low lockers shall not be hinged at the bottom. Doors of low lockers hinged at the bottom shall have not less than 5 cm ground clearance when open with the appliance fully laden.

4.8.10 Hose lockers of waterproof type shall have smooth floors. The height from the bottom to the top shall not be less than 550 mm and the depth of locker shall also be not less than 550 mm.

4.8.11 Doors, if required, shall be provided on both sides of the appliance giving ready access for the driver.

4.8.11.1 If doors are hinged and open outwards, they shall be hung forward and shall have locks with double striking plates. The doors or door locks shall be so designed as to prevent their being inadvertently opened from inside.

4.9 Ladder Gallows — The design of the gallows shall be such that it is possible to release the ladder without difficulty from a reasonably accessible position and shall embody rollers to permit easy withdrawal by one man. Means shall be provided for locking the ladder on the gallows. No equipment shall be so positioned as to interfere with the easy and independent removal of the ladder.

4.10 Tool-Kit Container — A specially fitted recessed tray, below the driver's seat, for the normal kit of tools carried on the appliance shall be provided, if required.

4.11 Stability — The stability of the appliance shall be such that under fully-equipped and loaded conditions but excluding crew, if the surface on which the appliance stands is tilted to either side, the point at which overturning occurs is not passed at an angle of $27\frac{1}{2}^{\circ}$ from the horizontal.

5. WORKMANSHIP AND FINISH

5.1 The standard of workmanship and finish of all parts shall be such that the parts normally required to be replaced can be supplied and fitted correctly.

5.2 The appliance shall be painted after proper cleaning and giving protective coat fire red on the outside with fire service insignia painted according to the purchaser's requirement. The appliance shall be painted suitably in the inside also.

6. INSTRUCTION BOOK, ACCESSORIES AND EQUIPMENT

6.1 Instruction Book — Three instruction books for the guidance of the user, including both operating and normal maintenance procedure, shall be supplied. The books shall include an itemized and illustrated spare parts list giving reference numbers of all the wearing parts with a view to ensuring that adequate number of such spare parts is made easily available when necessary.

6.2 Accessories — The following accessories shall also be provided in addition to those normally fitted as standard on modern commercial vehicles:

- a) *Fire Bell* — one 250-mm F-natural tone carillon fire bell (see IS : 928-1964*), shall be mounted externally and for operation from within the driver's enclosure.
- b) *Fog Lamps* — low mounted and of appropriate design.
- c) *Reversing Light* — a lamp suitably situated to assist reversing.
- d) *Trafficators* — with light on instrument panel or in any other prominent position in the driver's enclosure.
- e) *Wind Screen Wipers* — (electrically-operated) — two of approved design.
- f) *Tools* — all tools required for normal routine maintenance of the appliance which are not included in the standard kit of tools for chassis. These shall include 8 and 10 tonnes hydraulic jacks.
- g) *Connection for Tail Light of Trailer* — an efficient twin wire socket and plug for connecting the cable for the tail light of the trailer.
- h) *Search Light* — adjustable to give flood or beam light, mounted in a convenient position.
- j) *Spot Light, Adjustable* — mounted in a convenient position on the rear side of the driver's enclosure.
- k) *Inspection Lamp* — protected type on wander lead with plug. A socket shall be provided on the control panel in the driver's enclosure for plugging in the lamp.

6.3 Equipment — The appliance shall be provided with all or any selected items from the equipment detailed in Appendix A as required.

7. ACCEPTANCE TESTS

7.1 The appliance shall be subjected to the following tests. These tests

*Specification for fire bell (revised).

IS : 2696 - 1974

may be made at the manufacturer's works, fire brigade, or elsewhere, as required:

a) *Road Tests*

- 1) Acceleration and performance tests shall be made to check fulfilment of the requirements laid down in 2.2.
- 2) Braking test shall be made to check fulfilment of the requirement laid down in 2.3.
- 3) Turning circle test shall be made to check fulfilment of the requirements laid down in 4.1.1.

NOTE — For the purpose of road tests (1) and (2), the ladder shall be in position, and fuel tank shall be full, and all the scheduled equipment carried in designed stowage position, unless it is mutually agreed that a test load may be carried in lieu of the equipment.

- b) *Stability Test* — Stability test shall be made to check fulfilment of the requirements laid down in 4.11.
- c) *Pump Test* — In addition to tests to check that the pump fulfils the requirements laid down in 4.5.3, the pump shall be run for a continuous period of four hours delivering not less than the output specified in 4.5.3 at 3.0 m lift and at the atmospheric pressures given in 4.5.2. During the test, the temperature of engine cooling water and the lubricating oil shall not exceed 85°C and 79.5°C respectively.
- d) *Primer Test* — The primer shall be tested with a vertical lift of 7.0 m measured from the water level to the centre of the suction eye of the pump in order to check fulfilment of the requirements laid down in 4.6.

8. MANUFACTURER'S CERTIFICATE AND GUARANTEE

8.1 The manufacturer shall provide a certificate to the effect that the appliance conforms to the Indian Standard in every respect.

9. MARKING

9.1 Each appliance shall be clearly and permanently marked with the following information:

- a) Manufacturer's name or trade-mark, if any
- b) Capacity of the fire engine in l/min; and
- c) Year of manufacture.

APPENDIX A

(Clauses 4.1.1, 4.8.2 and 6.3)

SCHEDULE OF EQUIPMENT AND QUANTITY LIKELY
TO BE CARRIED ON THE APPLIANCE

Sl No.	Equipment	Quantity
1.	Suction hose, 75-mm size, 2.5-m length (see IS : 2410-1963*)	3
2.	Delivery hose, 63-mm size, lined (see IS : 636-1962†)	90 m
3.	Delivery hose, 63-mm size, unlined (see IS : 4927-1968‡)	90 m
4.	Suction adapter, 100-mm suction to 63-mm instantaneous hydrant outlet	1
5.	Suction wrenches for 75-mm size suction hose (see IS : 4643-1968§)	1 pair
6.	Branch pipe, ordinary (see IS : 903-1965)	1
7.	Nozzles, ordinary (see IS : 903-1965)	3
8.	Branch pipe universal (see IS : 2871-1964¶)	1
9.	Hydrant stand pipe, single head (see IS : 5714-1970**)	1
10.	Hydrant key (see IS : 910-1972††)	4
11.	Hose bandages (see IS : 5612-1969‡‡)	1
12.	Fire hook (see IS : 927-1964§§)	1
13.	Firemen's axe (see IS : 926-1970)	1

*Specification for suction hose of rubber for fire services.

†Specification for fire fighting hose (rubber lined woven-jacketed) (revised).

‡Specification for unlined flax canvas hose for fire fighting.

§Specification for suction wrenches for fire brigade use.

||Specification for fire hose delivery couplings, branch pipe, nozzles and nozzle spanner (revised).

¶Specification for branch pipe, universal, for fire fighting purposes.

**Specification for hydrant, stand-pipe for fire fighting.

††Specification for combined key for hydrant, hydrant cover and lower valve (first revision).

‡‡Specification for hose-clamps and hose-bandages for fire brigade use.

§§Specification for fire-hooks (revised).

||||Specification for firemen's axe (first revision).

IS : 2696 - 1974

<i>Sl No.</i>	<i>Equipment</i>	<i>Quantity</i>
14.	Crow bar (<i>see</i> IS : 704-1968*)	1
15.	Shovel [<i>see</i> IS : 274 (Part I and Part II)-1966†]	1
16.	Ladder (aluminium), extension 4.5-m size (<i>see</i> IS : 4571-1968‡)	1
17.	Insulated plier (<i>see</i> IS : 6078-1971§)	1
18.	First-aid box for six persons	1
19.	Torch flash light, 3 cells (<i>see</i> IS : 2083-1962)	2
20.	Fire buckets (<i>see</i> IS : 2546-1974¶)	4
21.	Fire extinguisher CO ₂ type (2 kg) (<i>see</i> IS : 2878-1964**)	1
22.	Metal strainer to suit 75 mm suction hose (<i>see</i> IS : 907-1965††)	1
23.	Basket strainer with canvas skirt (<i>see</i> IS : 3582-1966‡‡)	1
24.	Fire beater	1
25.	Ropes manila, 30 m (<i>see</i> IS : 1084-1969§§)	1

*Specification for crow-bars and claw-bars.

†Specification for shovels : Part I General purpose shovels, Part II Heat-treated shovels (*second revision*).

‡Specification for aluminium extension ladders for fire brigade use.

§Specification for lineman's pliers.

||Specification for flashlights.

¶Specification for galvanized mild steel fire bucket (*first revision*).

**Specification for portable fire extinguishers, carbondioxide type.

††Specification for suction strainers, cylindrical and shoe types, for fire fighting purposes (*revised*).

‡‡Specification for basket strainers for fire fighting purposes (cylindrical type).

§§Specification for manila ropes (*second revision*).

(Continued from page 2)

<i>Members</i>	<i>Representing</i>
SHRI H. C. RAI CHOUDHURY	Directorate General of Civil Aviation (Ministry of Tourism and Civil Aviation)
SHRI P. H. SETHNA	Kooverji Devshi & Co (P) Ltd, Bombay
SHRI N. T. PANJWANI (<i>Alternate</i>)	
SHRI C. R. SIRGAR	Directorate General of Supplies & Disposals (Ministry of Supply)
SHRI D. K. SIRKAR	Synthetics & Chemicals Ltd, Bareilly
SHRI R. S. SUNDARAM	Municipal Corporation of Delhi (Delhi Fire Service)
SHRI B. V. WAGLE	Directorate of Civil Defence (Operation), Govern- ment of Maharashtra, Bombay
SHRI R. R. RAO (<i>Alternate</i>)	

BUREAU OF INDIAN STANDARDS

Headquarters :

Manak Bhavan, 9 Bahadur Shah Zafar Marg, NEW DELHI 110002

Telephones 331 01 31

331 13 75

371 94 02

Telegrams Manaksanstha
(Common to all Offices)

Regional Offices :

	Telephone
Central Manak Bhavan, 9 Bahadur Shah Zafar Marg, NEW DELHI 110002	331 6617 335 3841
*Eastern 1/14 CIT Scheme VII M, V I P Road, Maniktola, CALCUTTA 700054	37 86 62
Northern SCO 335-336, Sector 34-A, CHANDIGARH 160022	60 38 43
Southern C I T Campus, IV Cross Road, MADRAS 600113	235 23 15
†Western Manakalaya, E9 MIDC, Marol, Andhen (East), BOMBAY 400093	832 92 95

Branch Offices :

'Pushpak', Nurmohamed Shaikh Marg, Khanpur, AHMADABAD 380001	30 13 48
‡Peenya Industrial Area, 1st Stage, Bangalore-Tumkur Road, BANGALORE 560058	839 49 55
Gangotri Complex, 5th Floor, Bhadbhada Road, T T Nagar, BHOPAL 462003	55 40 21
Plot No 21 Satyanagar BHUBANESHWAR 751007	40 36 27
Kalaikathir Building, 6/48 Avanashi Road, COIMBATORE 641037	21 01 41
Plot No 43, Sector 16 A, Mathura Road, FARIDABAD 121001	8-28 88 01
Savitri Complex, 116 G T Road, GHAZIABAD 201001	8-71 19 96
53/5 Ward No 29, R G Barua Road, 5th By-lane, GUWAHATI 781003	54 11 37
5-8-56C L N Gupta Marg, Nampally Station Road, HYDERABAD 500001	20 10 83
R 14, Yudhister Marg, C Scheme, JAIPUR 302005	38 13 74
117/418 B Sarvodaya Nagar, KANPUR 208005	21 68 76
Seth Bhawan, 2nd Floor, Behind Leela Cinema, Naval Kishore Road, LUCKNOW 226001	23 89 23
Patliputra Industrial Estate, PATNA 800013	26 23 05
T C No 14/1421, University P O , Palayam, THIRUVANANTHAPURAM 695034	6 21 17

Inspection Offices (With Sale Point)

Pushpanjali, 1st floor, 205-A, West High Court Road, Shankar Nagar Square, NAGPUR 440010	52 51 71
Institution of Engineers (India) Building 1332 Shivaji Nagar, PUNE 411005	32 36 35

* Sales Office is at 5 Chowringhee Approach, P O Princep Street,
CALCUTTA 700072 27 10 85

† Sales Office is at Novelty Chambers, Grant Road, BOMBAY 400007 309 65 28

‡ Sales Office is at 'F' Block, Unity Building, Narasimharaja Square,
BANGALORE 560002 222 39 71
