

इंटरनेट

मानक

Disclosure to Promote the Right To Information

Whereas the Parliament of India has set out to provide a practical regime of right to information for citizens to secure access to information under the control of public authorities, in order to promote transparency and accountability in the working of every public authority, and whereas the attached publication of the Bureau of Indian Standards is of particular interest to the public, particularly disadvantaged communities and those engaged in the pursuit of education and knowledge, the attached public safety standard is made available to promote the timely dissemination of this information in an accurate manner to the public.

“जानने का अधिकार, जीने का अधिकार”

Mazdoor Kisan Shakti Sangathan

“The Right to Information, The Right to Live”

“पुराने को छोड़ नये के तरफ”

Jawaharlal Nehru

“Step Out From the Old to the New”

IS 7320 (1974): Specification for concrete slump test apparatus [CED 2: Cement and Concrete]



“ज्ञान से एक नये भारत का निर्माण”

Satyanarayan Gangaram Pitroda

“Invent a New India Using Knowledge”



“ज्ञान एक ऐसा खजाना है जो कभी चुराया नहीं जा सकता है”

Bhartrhari—Nitiśatakam

“Knowledge is such a treasure which cannot be stolen”

BLANK PAGE



IS : 7320 -1974
(Reaffirmed 1999)
(Reaffirmed 2008)

Indian Standard

**SPECIFICATION FOR
CONCRETE SLUMP TEST APPARATUS**

(Fourth Reprint NOVEMBER 2000)

UDC 666.972 : 620.192.2.05



Copyright 1974

BUREAU OF INDIAN STANDARDS
MANAK BHAVAN, 9 BAHADUR SHAH ZAFAR MARG
NEW DELHI 110002

Gr 2

August 1974

Indian Standard

SPECIFICATION FOR CONCRETE SLUMP TEST APPARATUS

Cement and Concrete Sectional Committee, BDC 2

| <i>Chairman</i> | <i>Representing</i> |
|---|--|
| DR H. C. VISVESVARAYA | Cement Research Institute of India, New Delhi |
| <i>Members</i> | |
| DR. A. S. BHADURI | National Test House, Calcutta |
| SHRI E. K. RAMACHANDRAN (Alternate) | |
| SHRI A. K. CHATTERJI | Central Building Research Institute (CSIR), Roorkee |
| DR S. S. REHSI (Alternate) | |
| DEPUTY CHIEF ENGINEER (BUILDINGS) | Public Works Department, Government of Tamil Nadu |
| DEPUTY CHIEF ENGINEER (IRRIGATION & DESIGNS) (Alternate) | |
| DIRECTOR | Central Road Research Institute (CSIR), New Delhi |
| DR R. K. GHOSH (Alternate) | |
| DIRECTOR (CSMRS) | Central Water & Power Commission, New Delhi |
| DEPUTY DIRECTOR (CSMRS) (Alternate) | |
| SHRI K. H. GANGWAL | Hyderabad Asbestos Cement Products Ltd, Hyderabad |
| SHRI K. C. GHOSAL | Alokudyog Services Ltd, New Delhi |
| SHRI A. K. BISWAS (Alternate) | |
| DR R. K. GHOSH | Indian Roads Congress, New Delhi |
| BRIG HARISH CHANDRA | Engineer-in-Chief's Branch, Army Headquarters |
| SHRI G. R. MIRCHANDANI (Alternate) | |
| DR R. R. HATTIANGADI | Associated Cement Companies Ltd, Bombay |
| SHRI P. J. JAGUS (Alternate) | |
| DR IQBAL ALI | Engineering Research Laboratories, Hyderabad |
| JOINT DIRECTOR STANDARDS (B & S) | Research, Designs & Standards Organization, Lucknow |
| DEPUTY DIRECTOR STANDARDS (B & S) (Alternate) | |
| SHRI S. B. JOSHI | S. B. Joshi & Co Ltd, Bombay |
| SHRI M. T. KANSE | Directorate General of Supplies & Disposals |

(Continued on page 2)

© Copyright 1974

BUREAU OF INDIAN STANDARDS

This publication is protected under the *Indian Copyright Act* (XIV of 1957) and reproduction in whole or in part by any means except with written permission of the publisher shall be deemed to be an infringement of copyright under the said Act.

(Continued from page 1)

Members

SHRI S. L. KATHURIA
SHRI S. R. KULKARNI
SHRI M. A. MEHTA
SHRI O. MUTHACHEN
SUPERINTENDING ENGINEER,
2ND CIRCLE (Alternate)

SHRI ERACH A. NADIRSHAH
SHRI K. K. NAMBIAR

PROF G. S. RAMASWAMY

DR N. S. BHAL (Alternate)

DR A. V. R. RAO

SHRI K. S. SRINIVASAN (Alternate)

SHRI G. S. M. RAO

SHRI T. N. S. RAO

SHRI S. R. PINHEIRO (Alternate)

SECRETARY

DEPUTY SECRETARY (I) (Alternate)

SHRI R. P. SHARMA

SHRI MOHINDER SINGH (Alternate)

SHRI G. B. SINGH

SHRI C. L. KASLIWAL (Alternate)

SHRI J. S. SINGHOTA

SHRI T. C. GARG (Alternate)

SHRI R. K. SINHA

SHRI K. A. SUBRAMANIAM

SHRI P. S. RAMACHANDRAN (Alternate)

SHRI L. SWAROOP

SHRI A. V. RAMANA (Alternate)

SHRI D. AJITHA SIMHA,

Director (Civ Engg)

Representing

Roads Wing, Ministry of Shipping & Transport
M. N. Dastur & Co (Private) Ltd, Calcutta
Concrete Association of India, Bombay
Central Public Works Department

Institution of Engineers (India), Calcutta
In personal capacity ('Ramanalaya' 11 First Crescent
Park Road, Gandhinagar, Adyar, Madras)

Structural Engineering Research Centre (CSIR),
Roorkee

National Buildings Organization, New Delhi

Geological Survey of India, Nagpur

Ganmon India Ltd, Bombay

Central Board of Irrigation & Power, New Delhi

Irrigation & Power Research Institute, Amritsar

Hindustan Housing Factory Ltd, New Delhi

Beas Designs Organization, Nangal Township

Indian Bureau of Mines, Nagpur

India Cements Ltd, Madras

Dalmia Cement (Bharat) Ltd, New Delhi

Director General, ISI (Ex-officio Member)

Secretary

SHRI Y. R. TANEJA

Deputy Director (Civ Engg), ISI

Instruments for Cement and Concrete Testing Subcommittee, BDC 2 : 10

Convener

DR IQBAL ALI

Engineering Research Laboratories, Hyderabad

Members

PROF B. M. AHUJA

LALA G. C. DAS

SHRI T. P. EKAMBARAM

DR R. K. GHOSH

SHRI K. L. SETHI (Alternate)

Indian Institute of Technology, New Delhi

National Test House, Calcutta

Highways Research Station, Madras

Central Road Research Institute (CSIR), New Delhi

(Continued on page 8)

AMENDMENT NO. 1 MARCH 1984
TO
IS:7320-1974 SPECIFICATION FOR CONCRETE
SLUMP TEST APPATUS

Alterations

(Page 3, clause 2.1, line 2) - Substitute
'tamping bar' for 'tamping rod'.

(Page 4, clause 4, Title) - Substitute 'TAMPING
BAR' for 'TAMPING ROD'.

(Page 4, clause 4.1) - Substitute the following
for the existing matter:

'4.1 The tamping bar shall be a steel bar 16 mm in
diameter, 600 mm long with a rounded working end'

(Page 7, clause 5.1, line 2) - Substitute 'bar'
for 'rod'.

(BDC 2)

Indian Standard

SPECIFICATION FOR CONCRETE SLUMP TEST APPARATUS

0. FOREWORD

0.1 This Indian Standard was adopted by the Indian Standards Institution on 21 February 1974, after the draft finalized by the Cement and Concrete Sectional Committee had been approved by the Civil Engineering Division Council.

0.2 The Indian Standards Institution has already published a series of standards on methods of testing cement and concrete. It has been recognized that reliable and inter comparable test results can be obtained only with standard testing equipment capable of giving the desired level of accuracy. The Sectional Committee has, therefore, decided to bring out a series of specifications covering the requirements of equipment used for testing cement and concrete, to encourage its development and manufacture in the country.

0.3 For the purpose of deciding whether a particular requirement of this standard is complied with, the final value, observed or calculated, expressing the result of a test or analysis, shall be rounded off in accordance with IS : 2-1960*. The number of significant places retained in the rounded off value should be the same as that of the specified value in this standard.

1. SCOPE

1.1 This standard covers the requirements of the apparatus used for determining the slump of fresh concrete as a measure of its consistency.

2. APPARATUS

2.1 The apparatus shall consist of a mould for the test specimen and a tamping rod.

3. MOULD

3.1 Shape and Dimensions — The mould for the test specimen shall be in the form of the frustum of a cone as shown in Fig. 1 or 2 and internal dimensions as given in Table I.

*Rules for rounding off numerical values (*revised*).

TABLE 1 INTERNAL DIMENSIONS OF MOULD

(Clause 3.1)

| Sl. No. | DETAILS | DIMENSION mm | TOLERANCE (see NOTE) mm |
|---------|-----------------|-----------------|------------------------------|
| (1) | (2) | (3) | (4) |
| i) | Bottom diameter | 200 | + 3 - 1.5 |
| ii) | Top diameter | 100 | + 3 - 1.5 |
| iii) | Height | 300 | ± 1.5 |

NOTE — Diameter and height measured anywhere on the mould shall not differ from the nominal dimension (that is 200, 100 and 300 mm) by more than the specified tolerance.

3.1.1 Where no tolerance has been specified for a particular dimension, it will mean that reference is being made to the nominal dimension.

3.2 Material — The mould shall be made of galvanized iron sheet or any other suitable metal not readily attacked by cement paste; aluminium shall not be used. The metal shall be at least 1.6 mm thick.

3.3 Construction — The mould may be constructed either with or without a seam. When a seam is provided, the seam shall be essentially as shown in Fig. 2.

3.3.1 The top and bottom of the mould shall be open and parallel to each other and at right angles to the axis of the cone. The internal surface of the mould shall be smooth and shall be free from dents and projections, such as protruding rivets.

3.3.2 The mould shall be provided with foot pieces and handles to facilitate lifting it from the moulded concrete test specimen. The shape and dimensions of the foot pieces and handles may be as shown in Fig. 1 and 2. Attachments shall be riveted, welded or brazed to the mould. Any rivet used in the construction of the mould shall be countersunk on the inside of the cone.

NOTE — A mould which clamps to a non-absorbent base plate or an apparatus with a suitable guide attachment for measuring height of the moulded concrete may also be accepted provided it otherwise conforms to the requirements of the specification.

4. TAMPING ROD

4.1 The tamping rod shall be a round straight steel rod, 16 mm diameter and 600 mm long. The tamping end of rod shall be rounded to a hemispherical tip, the diameter of which shall be 16 mm.

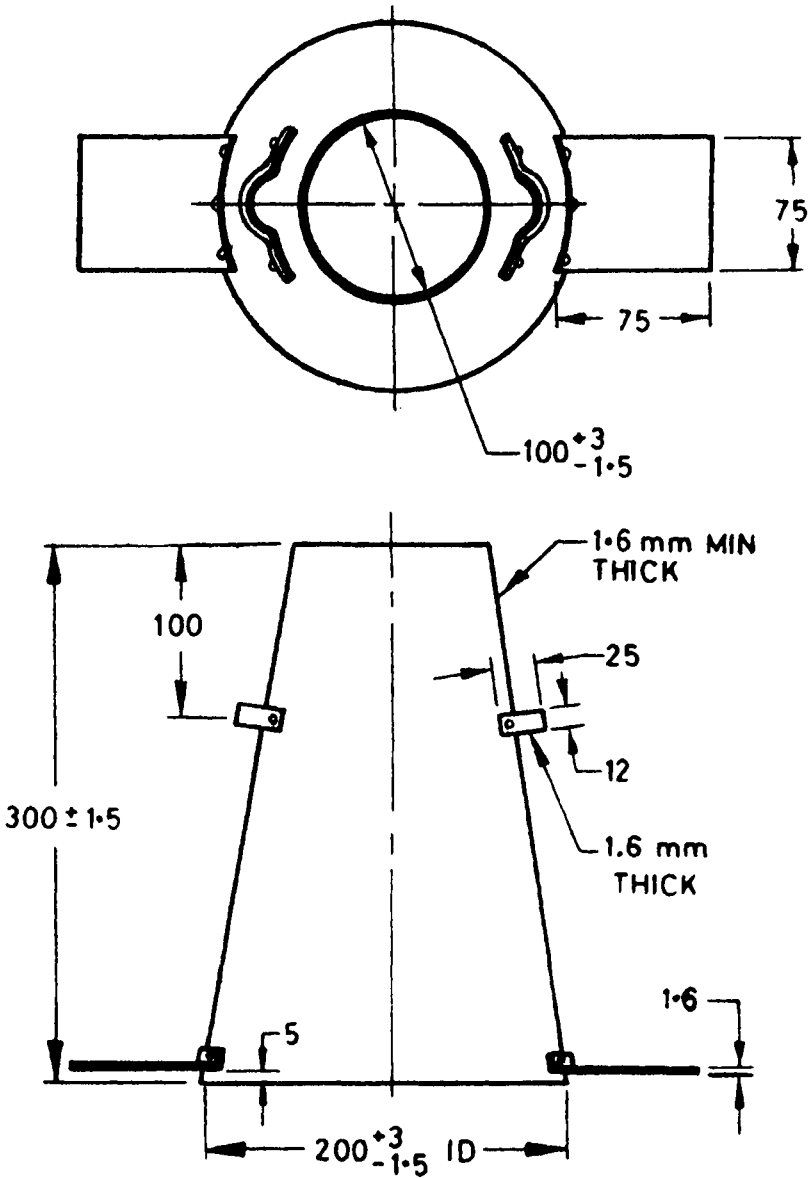

All dimensions in millimetres.

FIG. 1 MOULD (SEAMLESS) FOR SLUMP TEST OF CONCRETE

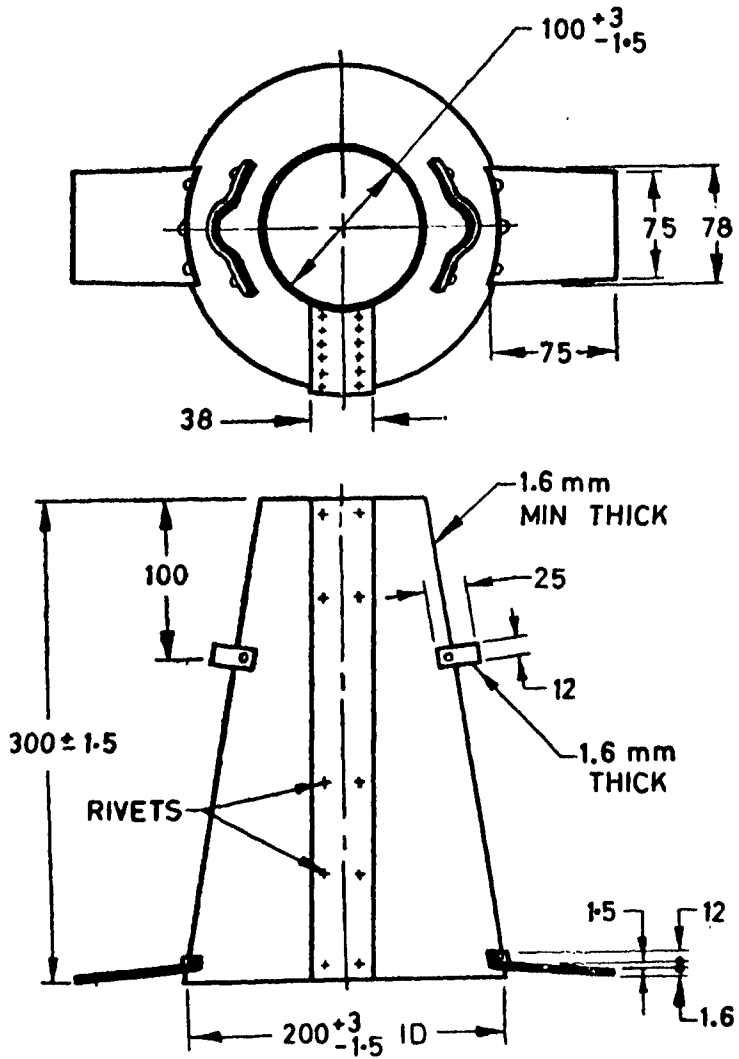

All dimensions in millimetres.

FIG. 2 A MOULD (WITH SEAM) FOR SLUMP TEST OF CONCRETE

5. MARKING

5.1 The following information shall be clearly and indelibly marked on the mould and the rod in a way that it does not interfere with the performance of this apparatus:

- a) Name of manufacturer or his registered trade-mark or both, and
- b) Date of manufacture.

5.1.1 The apparatus may also be marked with the Standard Mark.

5.1.2 The use of the Standard Mark is governed by the provisions of *Bureau of Indian Standards Act, 1986* and the Rules and Regulations made thereunder. The details of conditions under which the licence for the Standard Mark may be granted to manufacturers or producers may be obtained from the Bureau of Indian Standards.

IS : 7320 - 1974

(Continued from page 2)

| <i>Members</i> | <i>Representing</i> |
|--|---|
| SHRI H. K. GUHA | All India Instruments Manufacturers & Dealers Association, Bombay |
| SHRI V. K. VASUDEVAN (<i>Alternate</i>) | |
| SHRI P. J. JAGUS | Associated Cement Companies Ltd, Bombay |
| SHRI D. A. WADIA (<i>Alternate</i>) | |
| SHRI M. R. JOSHI | Ministry of Defence, R & D |
| SHRI K. A. SIRASKAR (<i>Alternate</i>) | |
| SHRI V. KANNAN | Cement Research Institute of India, New Delhi |
| SHRI M. V. RANGA RAO (<i>Alternate</i>) | |
| PROF C. K. RAMESH | Indian Institute of Technology, Bombay |
| DR R. S. AYYAR (<i>Alternate</i>) | |
| SHRI P. V. SUBBA RAO | Andhra Scientific Co Ltd, Masulipatam |
| SHRI Y. S. NARAYANA (<i>Alternate</i>) | |
| DR S. S. REHSI | Central Building Research Institute (CSIR), Roorkee |
| SHRI J. P. KAUSHISH (<i>Alternate</i>) | |
| SHRI H. C. VERMA | Associated Instrument Manufacturers (India) Pvt Ltd, New Delhi |
| SHRI A. V. SHASTRI (<i>Alternate</i>) | |

BUREAU OF INDIAN STANDARDS

Headquarters:

Manak Bhavan, 9 Bahadur Shah Zafar Marg, NEW DELHI 110002

Telephones: 323 0131, 323 3375, 323 9402

Fax : 91 11 3234062, 91 11 3239399, 91 11 3239387

Telegrams : Manaksanstha
(Common to all Offices)

Central Laboratory:

Plot No. 20/9, Site IV, Sahibabad Industrial Area, SAHIBABAD 201010

Telephone
8-77 00 32

Regional Offices:

| | |
|---|-----------|
| Central : Manak Bhavan, 9 Bahadur Shah Zafar Marg, NEW DELHI 110002 | 323 76 17 |
| *Eastern : 1/14 CIT Scheme VII M, V.I.P. Road, Maniktola, CALCUTTA 700054 | 337 86 62 |
| Northern : SCO 335-336, Sector 34-A, CHANDIGARH 160022 | 60 38 43 |
| Southern : C.I.T. Campus, IV Cross Road, CHENNAI 600113 | 235 23 15 |
| †Western : Manakalaya, E9 Behind Marol Telephone Exchange, Andheri (East), MUMBAI 400093 | 832 92 95 |

Branch Offices:

| | |
|---|------------|
| 'Pushpak', Nurmohamed Shaikh Marg, Khanpur, AHMEDABAD 380001 | 550 13 48 |
| ‡Peenya Industrial Area, 1st Stage, Bangalore - Tumkur Road, BANGALORE 560058 | 839 49 55 |
| Gangotri Complex, 5th Floor, Bhadbhada Road, T. T. Nagar, BHOPAL 462003 | 55 40 21 |
| Plot No. 62-63, Unit VI, Ganga Nagar, BHUBANESHWAR 751001 | 40 36 27 |
| Karalkathir Buildings, 670 Avinashi Road, COIMBATORE 641037 | 21 01 41 |
| Plot No. 43, Sector 16 A, Mathura Road, FARIDABAD 121001 | 8-28 88 01 |
| Savitri Complex, 116 G. T. Road, GHAZIABAD 201001 | 8-71 19 96 |
| 53/5 Ward No. 29, R. G. Barua Road, 5th By-lane, GUWAHATI 781003 | 54 11 37 |
| 5-8-58C, L. N. Gupta Marg, Nampally Station Road, HYDERABAD 500001 | 20 10 83 |
| E-52, Chitaranjan Marg, C-Scheme, JAIPUR 302001 | 37 29 25 |
| 117/418 B, Sarvodaya Nagar, KANPUR 208005 | 21 68 76 |
| Seth Bhawan, 2nd Floor, Behind Leela Cinema, Naval Kishore Road, LUCKNOW 226001 | 23 89 23 |
| Patliputra Industrial Estate, PATNA 800013 | 26 23 05 |
| T. C. No. 14/1421, University P. O. Palayam, THIRUVANANTHAPURAM 695034 | 6 21 17 |
| NIT Building, Second Floor, Gokulpat Market, NAGPUR 440010 | 52 51 71 |
| Institution of Engineers (India) Building, 1332 Shivaji Nagar, PUNE 411005 | 32 36 35 |
| *Sales Office is at 5 Chowringhee Approach, P. O. Princep Street, CALCUTTA 700072 | 27 10 85 |
| †Sales Office is at Novelty Chambers, Grant Road, MUMBAI 400007 | 309 65 28 |
| ‡Sales Office is at 'F' Block, Unity Building, Narashimaraaja Square, BANGALORE 560002 | 222 39 71 |