

इंटरनेट

मानक

Disclosure to Promote the Right To Information

Whereas the Parliament of India has set out to provide a practical regime of right to information for citizens to secure access to information under the control of public authorities, in order to promote transparency and accountability in the working of every public authority, and whereas the attached publication of the Bureau of Indian Standards is of particular interest to the public, particularly disadvantaged communities and those engaged in the pursuit of education and knowledge, the attached public safety standard is made available to promote the timely dissemination of this information in an accurate manner to the public.

“जानने का अधिकार, जीने का अधिकार”

Mazdoor Kisan Shakti Sangathan

“The Right to Information, The Right to Live”

“पुराने को छोड़ नये के तरफ”

Jawaharlal Nehru

“Step Out From the Old to the New”

IS 7344 (1974): bamboo tent poles [CED 9: Timber and Timber Stores]



“ज्ञान से एक नये भारत का निर्माण”

Satyanarayan Gangaram Pitroda

“Invent a New India Using Knowledge”



“ज्ञान एक ऐसा खजाना है जो कभी चुराया नहीं जा सकता है”

Bhartrhari—Nitiśatakam

“Knowledge is such a treasure which cannot be stolen”

BLANK PAGE



IS : 7344 - 1974

(Reaffirmed 2010)

Indian Standard
**SPECIFICATION FOR
BAMBOO TENT POLES**

(Second Reprint AUGUST 1997)

UDC 685.531.054 : [633.584.5]

© *Copyright* 1974

BUREAU OF INDIAN STANDARDS
MANAK BHAVAN, 9 BAHADUR SHAH ZAFAR MARG
NEW DELHI 110002

Indian Standard

SPECIFICATION FOR BAMBOO TENT POLES

Timber Stores Sectional Committee, BDC 33

Chairman

DR A. N. NAYER
117/K/18-D Sarvodaya Nagar
Kanpur (U.P.)

Members

SHRI S. K. CHANDA
SHRI S. N. DHIR
SHRI L. N. DOKANIA

SHRI G. L. KEDIA (*Alternate*)

SHRI S. N. GARG

SMT S. GURUSWAMY

DR S. KRISHNA SWAMY

SHRI J. S. MATHURU

SHRI P. V. MEHTA (*Alternate*)

COL Y. P. MISRA

SHRI D. P. GHOSH (*Alternate*)

LT-COL S. A. MOHILE

SHRI B. B. MEHTA (*Alternate*)

SHRI A. C. SEKHAR

OFFICER-IN-CHARGE, WOOD

SEASONING BRANCH (*Alternate I*)

OFFICER-IN-CHARGE, WOOD

PRESERVATION BRANCH (*Alternate II*)

SHRI SHARAN SINGH

SHRI M. S. VAGH

SHRI P. M. THOMAS (*Alternate*)

SHRI D. AJITHA SIMHA,

Director (Civ Engg)

Representing

Industrial Wood Works (Private) Ltd, Calcutta
Ministry of Defence (DGOF)
Plywood Manufacturers' Association of India,
Calcutta

Govind Narain & Brothers, Kanpur

Curzon and Company, Madras

Railway Board (Ministry of Railways)

Directorate General of Technical Development

Ministry of Defence (DGI)

Ministry of Defence (R & D)

Forest Research Institute & Colleges, Dehra Dun

Directorate General of Supplies & Disposals

South Indian Plywood Manufacturers' Association,
Calicut

Director General, BIS (*Ex-officio Member*)

Secretary

SHRI J. R. MENTA
Deputy Director (Civ Engg), BIS

© Copyright 1974

BUREAU OF INDIAN STANDARDS

This publication is protected under the *Indian Copyright Act* (XIV of 1957) and reproduction in whole or in part by any means except with written permission of the publisher shall be deemed to be an infringement of copyright under the said Act.

AMENDMENT NO. 1 OCTOBER 1978
TO
IS : 7344-1974 SPECIFICATION FOR
BAMBOO TENT POLES

Alterations

(Page 3, clause 3.3, line 1) — Substitute ' IS : 3252-1975* ' for ' IS : 3252-1965* '.

(Page 3, foot-note with ' * ' mark) — Substitute the following for the existing foot-note:

**Specification for shroud-laid cotton line (first revision).'

(Page 5, clause 7.1, informal table, second column, against ' Xylocopa holes ') — Substitute ' One per pole ' for ' One per hole '.

[Page 6, clause 8.1(b), heading] — Substitute ' Bamboos with Cavity of Diameter Not Exceeding 15 mm ' for ' Bamboos with Cavity not Exceeding 15 mm '.

(Pages 8 and 9, Fig. 2, informal table, twelfth column) — Substitute the following for the existing matter:

Line Cotton
T
6 circ × 2 340 long
6 circ × 1 980 long
Not Required
4 circ × 1 525 long
4 circ × 1 675 long
4 circ × 1 675 long

(Page 14, Fig. 3C, informal table, fifth column) — Substitute the following for the existing matter:

Line Cotton
T
4 circ × 1 525 long
4 circ × 1 675 long
4 circ × 1 525 long

(Pages 17, Fig. 4, legend) — Substitute ' END WHIPPED, SEWN OR KNOTTED ' for ' END WHIPPED AND SEWN '.

(Page 18, clause 8.1.1, formula) — Substitute the following for the existing formula:

$$\begin{aligned} &\text{No. of cubic centimetres (millilitres)} \\ &\text{of the preservative required to be} \\ &\text{injected per internode} \end{aligned} = \frac{L \times L \times T}{16}$$

(BDC 33)

Indian Standard SPECIFICATION FOR BAMBOO TENT POLES

0. FOREWORD

0.1 This Indian Standard was adopted by the Indian Standards Institution on 15 March 1974, after the draft finalized by the Timber Stores Sectional Committee had been approved by the Civil Engineering Division Council.

0.2 The demand for bamboo tent poles is on the increase because large quantities are being used for pitching tents. A variety of sizes and qualities are being manufactured making it difficult to select the correct size and quality. This standard has, therefore, been prepared for laying down standard sizes and other requirements in respect of bamboo tent poles with a view to easing the manufacture and supply of such poles.

0.3 In the formulation of this standard, due weightage has been given to the international co-ordination among the standards and practices prevailing in different countries in addition to relating it to the practices in the field in this country.

0.4 For the purpose of deciding whether a particular requirement of this standard is complied with, the final value, observed or calculated, expressing the result of a test or analysis, shall be rounded off in accordance with IS: 2-1960*. The number of significant places retained in the rounded off value should be the same as that of the specified value in this standard.

1. SCOPE

1.1 This standard covers requirements of the following three types of bamboo poles for use with various tents:

- a) Wall,
- b) Standing, and
- c) Ridge.

2. TERMINOLOGY

2.0 For the purpose of this standard, the following definitions shall apply.

2.1 Adequately Seasoned Bamboo — Bamboo felled not less than six weeks before processing into poles.

2.2 Burr — The turned up edge of metal resulting from the operation of punching, drilling and cutting.

*Rules for rounding off numerical values (*revised*).

- 2.3 Collapse** — A deep depression in internode which results in the cracking of the internal shell wall.
- 2.4 Correctly Paired** — The two halves of a pole are said to be correctly 'Paired' when they are not excessively loose within socket.
- 2.5 Dead Bamboo** — The bamboo which has died after flowering or injury to its stem. It is distinguishable by its dull greyish colour, lightness in weight and its brittleness.
- 2.6 Excessive Charring** — Charring deeper than 3 mm.
- 2.7 'GHOON' Holes** — Holes caused by the activities of *Dinoderus* beetles.
- 2.8 Immature Bamboo** — The bamboo having bud scars on the stem. It is distinguishable by its dull yellowish colour.
- 2.9 Internode** — The portion of a bamboo between two nodes.
- 2.10 Node** — The place on the stem from which the branches shoot off.
- 2.11 Objectionable Crack** — A separation of the fibres in the longitudinal direction which extends beyond 3 mm in the depth of the skin of a bamboo and beyond a node.
- 2.12 Reasonably Straight Bamboo** — Bamboo out of straight by not more than one diameter.
- 2.13 Shell** — The wall of a bamboo.
- 2.14 Split** — A separation of the fibres in the longitudinal direction, completely rupturing the shell wall.
- 2.15 Top End of Bamboo** — The tapered end (thin end) of bamboo where the shell thickness is lesser than the other end.

3. MATERIAL

3.1 Bamboo — Any species of bamboo may be used. The bamboo shall be mature, sound (not dead), reasonably straight and adequately seasoned. It shall be free from 'GHOON' holes, any kind of decay (rot), collapse, splits, objectionable cracks, cuts across the grain and excessive charring and any other defect except those permitted in the finished holes as mentioned under 7 which is likely to reduce the usefulness of fabricated pole.

3.1.1 The internodal distance shall not exceed 45 cm.

3.2 Mild Steel — Rust-free mild steel shall be used for the various metal components.

3.3 Line-Cotton Undyed — Line cotton shall conform to IS: 3252-1965*.

*Specification for shroud-laid cotton line.

3.4 Cotton Thread — Cotton thread shall be of size designation 50 tex \times 4 (or 12₈/4) conforming to variety 44 of IS : 1720-1969*.

4. MANUFACTURE

4.1 The wall, standing and ridge poles shall be manufactured to the shape and design as shown in Fig. 1, 2 and 3 respectively.

4.2 The hollow ends of bamboos shall be securely and tightly closed with solid bamboo plugs or wooden plugs, which shall be properly glued. The plugs shall extend from the ends of the pole to a distance of 25 mm from the next node. The bamboos may be rasped for fitting of metal components; provided the rasping is not deeper than 1.5 mm and the rasped portions are liberally swabbed with neat (undiluted) creosote oil.

4.3 Bamboos for ridge poles, except for poles No. 7 and 8 shall have the ends rounded to fit into domes of the caps. Plugging of the cavity in ridge poles, where the cap is fitted, shall only be done when the diameter of the cavity in the bamboo is greater than the width of the slot in the cap.

4.4 Bamboos for ridge poles No. 7 and 8 shall be cut-flat at the end for fitting the loops and hooks.

4.5 Jointed Poles

4.5.1 Standing Poles — The two halves of the pole shall be correctly 'paired'. The socket shall be properly positioned and correctly riveted to the top end of the lower half, the bottom end of the upper half shall be an even fit into the socket.

4.5.2 Ridge Poles — The two halves of the pole shall be correctly 'paired' and the socket shall be properly positioned and correctly riveted.

4.5.3 Both for standing poles and ridge poles, bamboo shall not be used in the inverted position.

4.5.4 Line cotton, undyed of the specified length shall be securely fastened to the two halves of a pole. The ends of the line cotton shall be whipped and sewn with thread, cotton 12₈/4. The method of securing line cotton is shown in Fig. 4.

4.6 Bands — The bands shall be manufactured out of mild steel sheets of 1.6 mm nominal thickness. The bands shall be butt-jointed and welded. Alternatively, bands may be manufactured from electric resistance welded (ERW) steel tubings.

4.7 Caps — The caps shall be manufactured out of 1.6 mm mild steel sheets. The joints in caps shall be neatly and properly welded. Alternatively, pressed steel caps may be used.

*Specification for cotton sewing threads.

4.8 Loops and Hooks — The loops and hooks shall be made from a single piece of mild steel. Loops and hooks shall be manufactured out of 5 mm thick mild steel sheets. The eyes of the loops shall be punched.

4.9 Sockets — The sockets shall be butt-jointed and welded. They shall then be fitted with solid strengthening bands made of mild steel 13 × 5 mm in cross section. The strengthening bands shall be properly spot-welded to the cylinder of the sockets. The spot welding shall be done at 4 spots equally spaced around the periphery of the cylinder. Alternatively, sockets manufactured from electric resistance welded (ERW) steel tubing of 3 mm wall thickness may be used without the strengthening bands.

4.10 Spikes — The spikes consisting of mild steel rounds shall be slightly tapered at the lower end and slightly rounded at the top. The holes for rivets shall be either forged or drilled. The spikes shall be correctly positioned and properly fitted to the top end of bamboo as shown in Fig. 2.

4.11 Cross Pin — The cross pins shall be of 6 mm dia mild steel rounds.

5. DIMENSIONS AND TOLERANCES

5.1 Dimensions — The poles shall conform to the dimensions as shown in Fig. 1, 2 and 3.

5.2 Tolerances — Where tolerances on dimensions are not shown in Fig. 1, 2 and 3, normal manufacturing tolerances shall be permissible on all dimensions.

6. WORKMANSHIP AND FINISH

6.1 The nodal portions of bamboo shall be smoothly finished. The metal components shall be free from sharp edges, cracks and burrs. The welding of the joints shall be clean, continuous and sound. All the metal components shall be properly and correctly fitted and the ends of rivets properly snapped. Eyes of the loops and caps shall be properly made and smoothly finished.

7. PERMISSIBLE DEFECTS

7.1 Defects to the following extent shall be permissible in the finished poles:

<i>Defect</i>	<i>Extent of Permissible Defects</i>
Dead skin	Up to 4 internodes
Water marks	Up to 4 internodes
Xylocopa holes	One per hole
Estigmina attack	Not deeper than 3 mm
Knife cuts and charring	Not deeper than 3 mm
Rasping	Not deeper than 3 mm

8. PRESERVATION

8.1 Unless otherwise specified, the poles shall be treated as follows:

- a) The poles shall be thoroughly cleaned and metal components free from all traces of rust and foreign deposition before the preservative treatment is carried out;
- b) *Bamboos with Cavity not Exceeding 15 mm* — The poles shall be preserved by complete immersion in creosote oil conforming to Type II of IS : 218-1961* for a minimum period of 18 h at room temperature. Alternatively, the poles may be preserved by complete immersion in neat and hot (about 90°C) creosote oil for a minimum period of 30 min, immediately followed by complete immersion in neat creosote oil at room temperature for a minimum period of 30 min; and
- c) *Bamboos with Cavity Exceeding 15 mm* — Each internode of the pole shall be drilled by the supplier with 6-mm diameter hole into the cavity, 13 mm below the node. All the holes shall be on the same side of each node and in one straight line. The poles shall then be preserved by injecting the requisite quantity of neat creosote oil conforming to Type II of IS : 218-1961* at room temperature, using an injection syringe. The holes shall then be plugged with bamboo pieces. The poles shall then be inverted, rolled down a gentle slope and placed in nearly vertical position for at least 48 h.

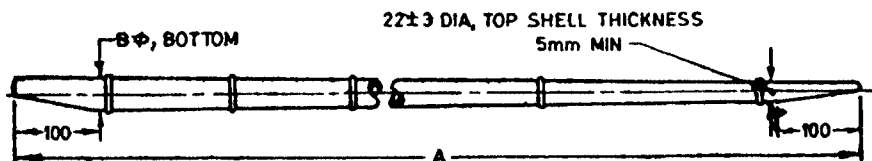

Pole No.	Dimension	Bottom Dia
	A	B
Pole No. 1	2 100 ± 10	40 ⁺⁰ -10
Pole No. 2	1 640 ± 10	30 ⁺⁰ -5
Pole No. 3	1 560 ± 10	30 ⁺⁰ -5
Pole No. 4	1 780 ± 10	30 ⁺⁰ -5

IA POLES NO. 1, 2, 3 AND 4

All dimensions in millimetres.

FIG. 1 WALL POLES NO. 1 TO 7 — *Contd*

*Specification for creosote and anthracene oil for use as wood preservative (revised).

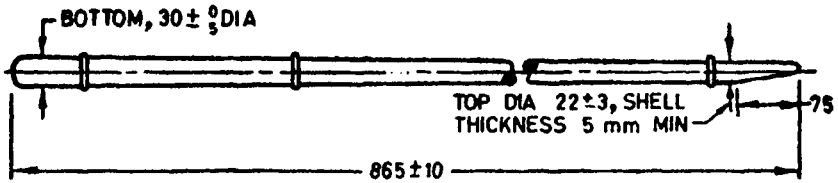

IB POLE NO. 5

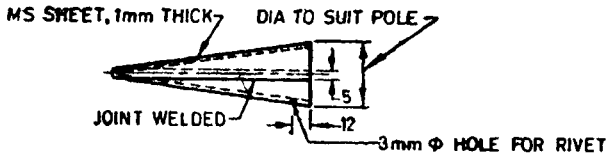
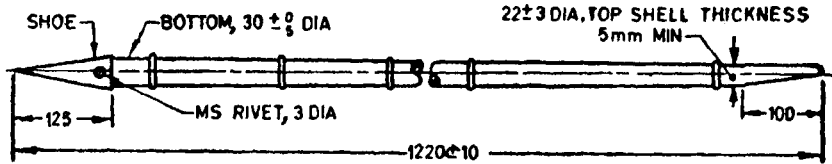

DETAILS OF SHOE

IC POLE NO. 6

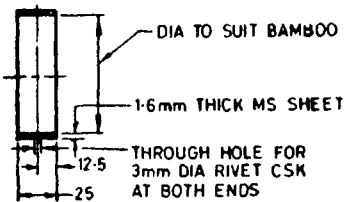
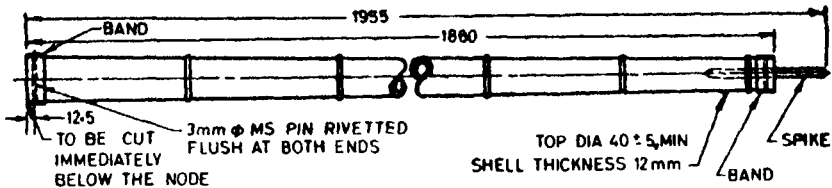

BAND

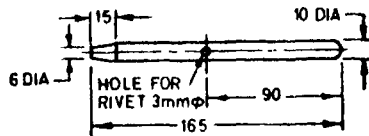

MS SPIKE

ID POLE NO. 7

All dimensions in millimetres.

FIG. 1 WALL POLES NO. 1 TO 7

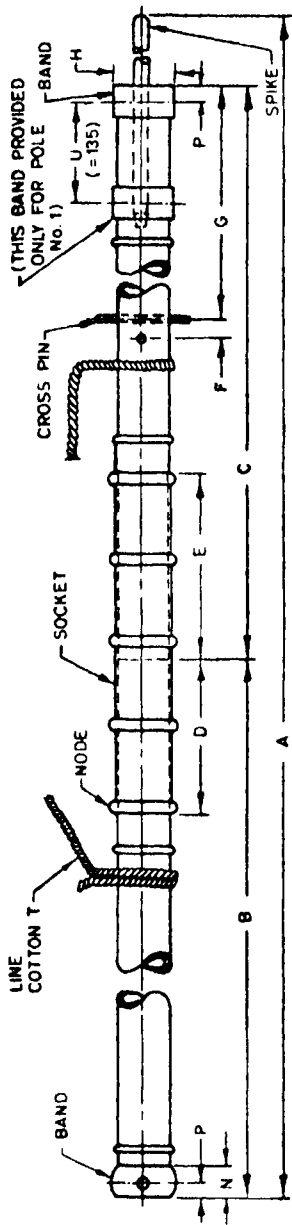

2A POLES NO. 1, 2, 4, 5 AND 6

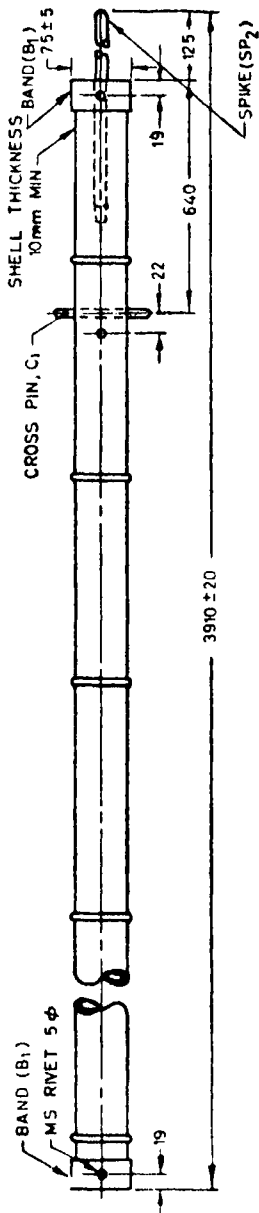

2B POLE NO. 3

Pole No.	A	B	C	Socket		F	G	Top Dia H	Minimum Thickness of Shell at Top	U	Line Cotton T	Socket	Spike	Cross Pin	Band
				D	E										
1	4 930 ± 20	2 340 ± 10	2 390 ± 10	200	250	22	640	75 ± 5	12.5	135	19 circ × 2 340 long	S ₁	SP ₁	C ₁	B ₁
2	3 580 ± 20	1 690 ± 10	1 765 ± 10	175	200	22	435	75 ± 5	10	—	19 circ × 1 980 long	S ₂	SP ₂	C ₁	B ₁
3	3 910 ± 20	—	—	—	—	22	640	75 ± 5	10	—	Not Required	—	SP ₂	C ₁	B ₁
4	2 055 ± 10	950 ± 5	1 030 ± 5	100	150	—	—	30 ± 4	10	—	12.5 circ × 1 525 long	S ₂	SP ₂ Not Re- quired	Not Re- quired	B ₂
5	2 360 ± 10	1 100 ± 5	1 185 ± 5	100	150	22	175	45 ± 5	5	—	12.5 circ × 1 675 long	S ₂	SP ₂	C ₂	B ₂
6	2 540 ± 10	1 200 ± 5	1 240 ± 5	100	150	22	175	45 ± 5	5	—	12.5 circ × 1 675 long	S ₂	SP ₂	C ₂	B ₂

All dimensions in millimetres.

FIG. 2 STANDING POLES No. 1 TO 6 — Contd

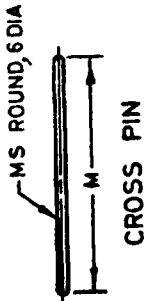
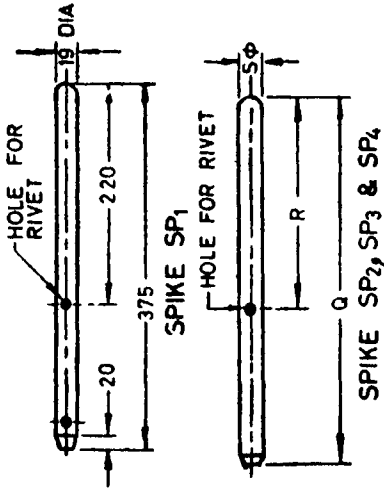

Designation	M	Used for Pole No.	Q	R	S	Hole for Rivets (φ)	Used for Pole No.
C ₁	125	1, 2 and 3	See Sketch			5	1
C ₂	75	5 and 6	290	145	19	5	2 and 3
			200	115	12.5	5	6
			165	90	10	3-15	4 and 5

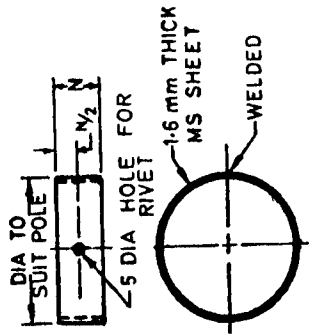
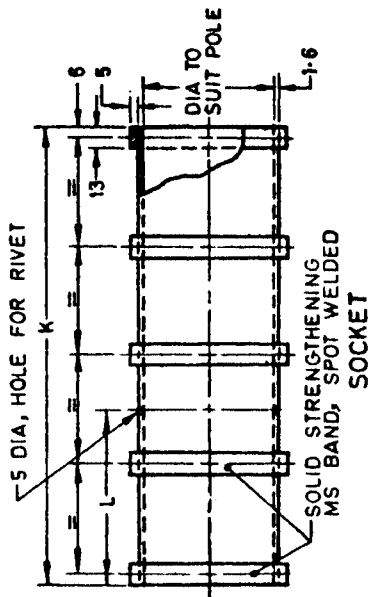

Designation	Size		Designation	Size	Used for Pole No.	
	N	P				K
B ₁	38	19	S ₁	450	170	1
B ₂	25	12.5	S ₂	375	90	2
			S ₃	250	60	4, 5 and 6

2C DETAILS OF ACCESSORIES FOR STANDING POLES NO. 1 TO 6

All dimensions in millimetres.

FIG. 2 STANDING POLES No. 1 TO 6

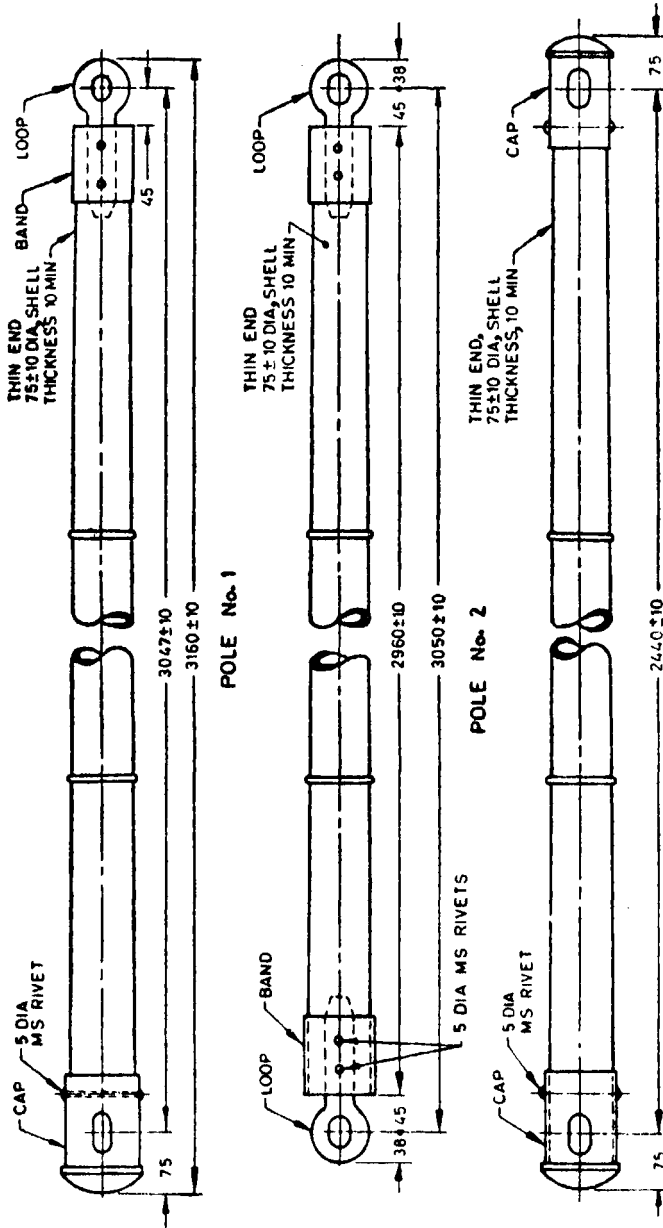

POLE No. 1
POLE No. 2
POLE No. 3
3A RIDGE POLES (WITHOUT SOCKET) NO. 1, 2 AND 3

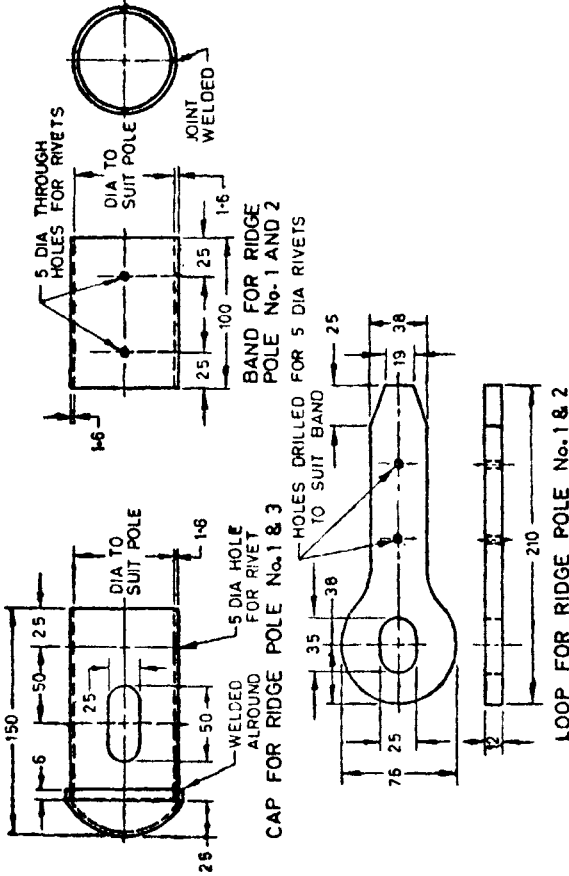

3B DETAILS OF ACCESSORIES FOR RIDGE POLES (WITHOUT SOCKET) NO. 1, 2 AND 3

All dimensions in millimetres.

FIG. 3 RIDGE POLES No. 1 TO 8 — Contd

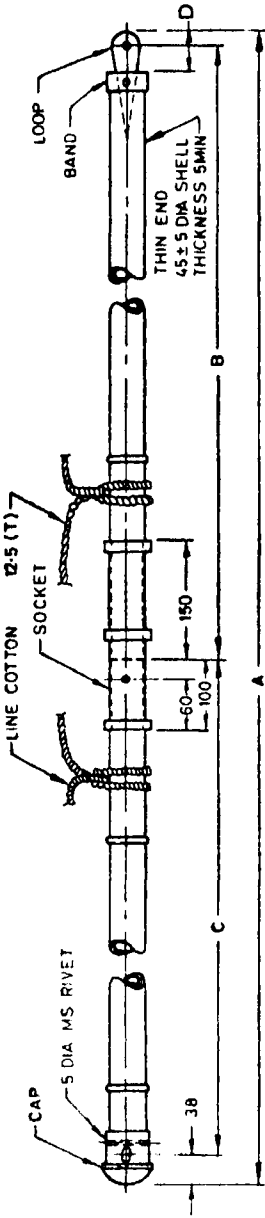

Detail	A	B	C	Line Cotton T	Fittings at Ends	Remarks
Pole No. 4	2 160 ± 10	1 138 ± 10	965 ± 10	12.5 circ × 1 525 long	Loop and band shall be fitted on one end. Cap shall be fitted on the other end	i) Projection due to the fitting of cap shall be 38
Pole No. 5	2 440 ± 10	1 260 ± 10	1 100 ± 10	12.5 circ × 1 675 long	Cap shall be fitted on both the ends	ii) Projection due to the fittings of loop and band, that is, D shall be 50
Pole No. 6	2 130 ± 10	1 105 ± 10	950 ± 10	12.5 circ × 1 525 long	Cap shall be fitted on both the ends	

3C RIDGE POLES (WITH SOCKET) NO. 4, 5 AND 6

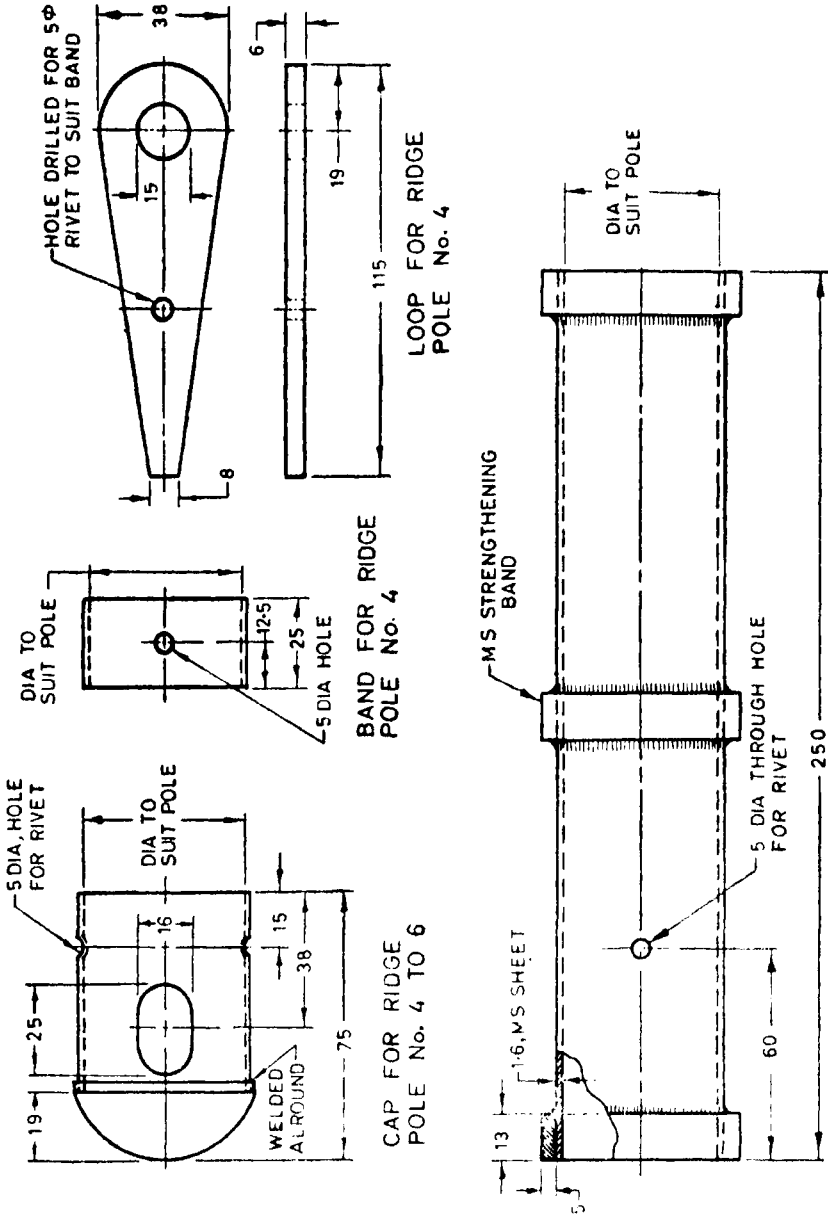

3D DETAILS OF ACCESSORIES FOR RIDGE POLES (WITH SOCKET) NO. 4 TO 6

All dimensions in millimetres.

FIG. 3 RIDGE POLES No. 1 TO 8—Contd

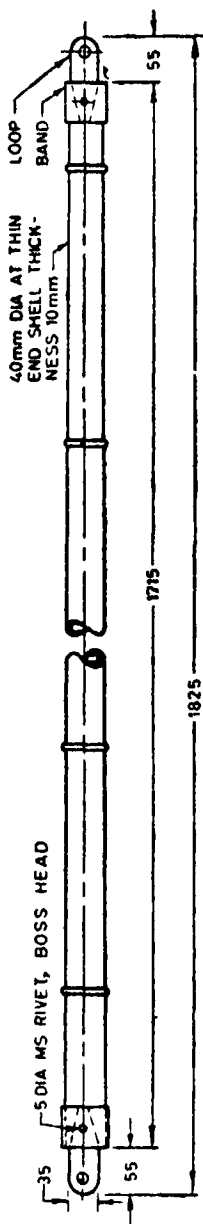

POLE No. 7

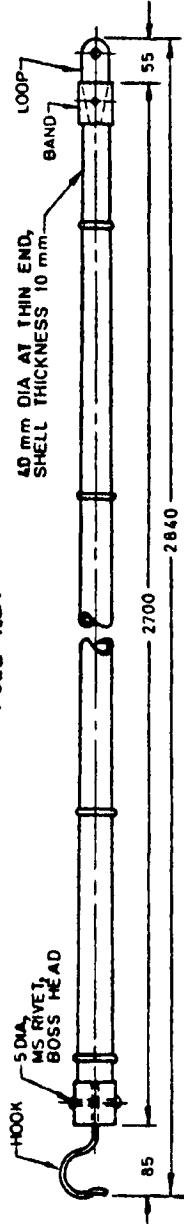

POLE NO. 8

3E RIDGE POLES (TENT-POLES) NO. 7 AND 8

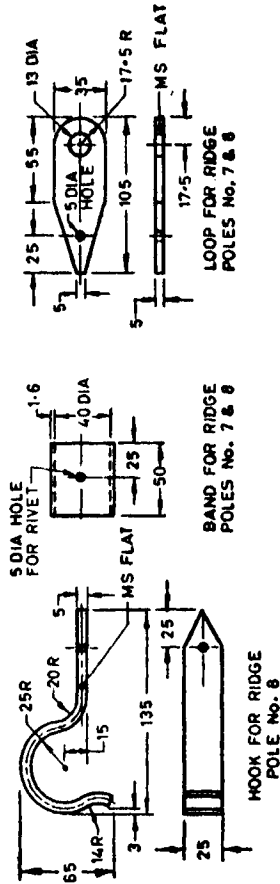

3F DETAILS OF ACCESSORIES FOR RIDGE POLES (TENT-POLES) NO. 7 AND 8

All dimensions in millimetres.

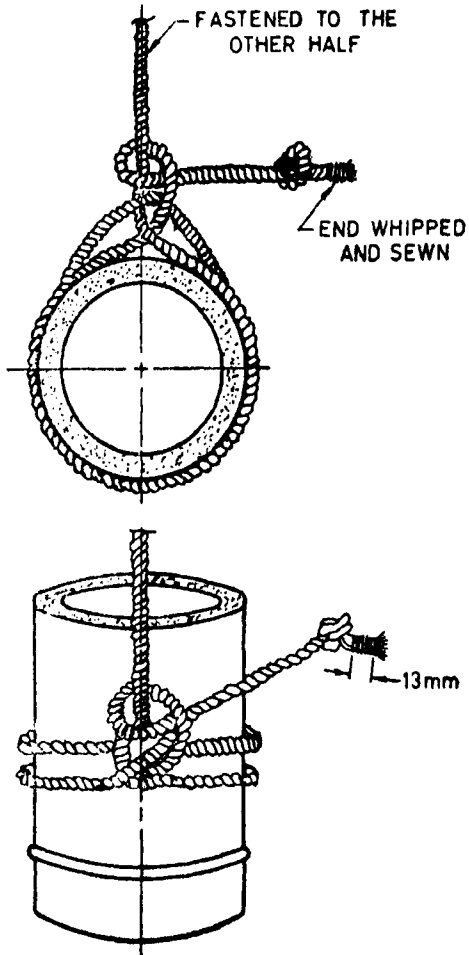

FIG. 4 METHOD OF SECURING LINE COTTON TO THE POLE

IS : 7344 - 1974

8.1.1 The requisite quantity of the preservative (creosote oil) shall be determined by the following formula:

$$\text{No. of cubic centimetres (cubic millilitres) of the preservative required to be injected per internode} = \frac{L \times D \times T}{16}$$

where

L = average length of the internode of a pole in cm,

D = average diameter of the internode at the bigger end in cm,
and

T = average thickness of the shell at the bigger end in cm.

8.1.2 The metal components, after wiping off the preservative, shall be brush treated at room temperature using temporary corrosion preventive, fluid, hard film, solvent deposited conforming to IS : 1153-1957*.

9. MARKING

9.1 Unless otherwise specified, each pole/both halves of a jointed pole shall be legibly and indelibly marked with the following information:

- a) The supplier's name or initials or recognized trade-mark, if any ;
- b) The year of supply; and
- c) The type and number of the pole.

9.2 BIS Certification Marking

The product may also be marked with Standard Mark.

9.2.1 The use of the Standard Mark is governed by the provisions of the Bureau of Indian Standards Act, 1986 and the Rules and Regulations made thereunder. The details of conditions under which the licence for the use of Standard Mark may be granted to manufacturers or producers may be obtained from the Bureau of Indian Standards.

*Specification for temporary corrosion preventive, fluid, hard film, solvent deposited.

BUREAU OF INDIAN STANDARDS

Headquarters:

Manak Bhavan, 9 Bahadur Shah Zafar Marg, NEW DELHI 110002

Telephones: 323 0131, 323 3375, 323 9402

Fax : 91 11 3234062, 91 11 3239399, 91 11 3239382

Telegrams : Manaksanstha
(Common to all Offices)

Central Laboratory:

Plot No. 20/9, Site IV, Sahibabad Industrial Area, SAHIBABAD 201010

Telephone
8-77 00 32

Regional Offices:

Central : Manak Bhavan, 9 Bahadur Shah Zafar Marg, NEW DELHI 110002 323 76 17
*Eastern : 1/14 CIT Scheme VII M, V.I.P. Road, Maniktola, CALCUTTA 700054 337 86 62
Northern : SCO 335-336, Sector 34-A, CHANDIGARH 160022 60 38 43
Southern : C.I.T. Campus, IV Cross Road, CHENNAI 600113 235 23 15
†Western : Manakalaya, E9 Behind Marol Telephone Exchange, Andheri (East),
MUMBAI 400093 832 92 95

Branch Offices:

'Pushpak', Nurmohamed Shaikh Marg, Khanpur, AHMEDABAD 380001 550 13 48
‡Peenya Industrial Area 1st Stage, Bangalore - Tumkur Road,
BANGALORE 560058 839 49 55
Gangotri Complex, 5th Floor, Bhadbhada Road, T. T. Nagar, BHOPAL 462003 55 40 21
Plot No. 62-63, Unit VI, Ganga Nagar, BHUBANESHWAR 751001 40 36 27
Kalaikathir Buildings, 670 Avinashi Road, COIMBATORE 641037 21 01 41
Plot No. 43, Sector 16 A, Mathura Road, FARIDABAD 121001 8-28 88 01
Savitri Complex, 116 G. T. Road, GHAZIABAD 201001 8-71 19 96
53/5 Ward No. 29, R. G. Barua Road, 5th By-lane, GUWAHATI 781003 54 11 37
5-8-58C, L. N. Gupta Marg, Nampally Station Road, HYDERABAD 500001 20 10 83
E-52, Chitaranjan Marg, C-Scheme, JAIPUR 302001 37 29 25
117/418 B, Sarvodaya Nagar, KANPUR 208005 21 68 76
Seth Bhatnagar, 2nd Floor, Behind Leela Cinema, Naval Kishore Road,
LUCKNOW 226001 23 89 23
Patliputra Industrial Estate, PATNA 800013 26 23 05
T. C. No. 14/1421, University P. O. Palayam,
THIRUVANANTHAPURAM 695034 21 17
NIT Building, Second Floor, Gokulpat Market, NAGPUR 440010 52 51 71
Institution of Engineers (India) Building, 1332 Shivaji Nagar, PUNE 411005 32 36 35

*Sales Office is at 5 Chowringhee Approach, P. O. Princep Street,
CALCUTTA 700072 27 10 85
†Sales Office is at Novelty Chambers, Grant Road, MUMBAI 400007 309 65 28
‡Sales Office is at 'F' Block, Unity Building, Narashimaraja Square,
BANGALORE 560002 222 39 71