

इंटरनेट

मानक

### Disclosure to Promote the Right To Information

Whereas the Parliament of India has set out to provide a practical regime of right to information for citizens to secure access to information under the control of public authorities, in order to promote transparency and accountability in the working of every public authority, and whereas the attached publication of the Bureau of Indian Standards is of particular interest to the public, particularly disadvantaged communities and those engaged in the pursuit of education and knowledge, the attached public safety standard is made available to promote the timely dissemination of this information in an accurate manner to the public.

“जानने का अधिकार, जीने का अधिकार”

Mazdoor Kisan Shakti Sangathan

“The Right to Information, The Right to Live”

“पुराने को छोड़ नये के तरफ”

Jawaharlal Nehru

“Step Out From the Old to the New”

IS 8413-1 (1977): Requirements for biological treatment equipment, Part 1: Trickling filters [CED 24: Public Health Engineering.]



“ज्ञान से एक नये भारत का निर्माण”

Satyanarayan Gangaram Pitroda

“Invent a New India Using Knowledge”



“ज्ञान एक ऐसा खजाना है जो कभी चुराया नहीं जा सकता है”

Bhartrhari—Nitiśatakam

“Knowledge is such a treasure which cannot be stolen”



BLANK PAGE



“पुनः १९९६”  
“RE-AFFIRMED 1996”  
IS : 8413 ( Part I ) - 1977

*Indian Standard*  
REQUIREMENTS FOR BIOLOGICAL  
TREATMENT EQUIPMENT

**PART I TRICKLING FILTERS**

( First Reprint MAY 1983 )

UDC 628'353'1



© Copyright 1977

**INDIAN STANDARDS INSTITUTION**  
MANAK BHAVAN, 9 BAHADUR SHAH ZAFAR MARG  
NEW DELHI 110002

*Indian Standard*REQUIREMENTS FOR BIOLOGICAL  
TREATMENT EQUIPMENT

## PART I TRICKLING FILTERS

Public Health Engineering Equipment Sectional Committee, BDC 40

*Chairman*

SHRI T. S. SWAMY

*Representing*

Central Public Health and Environmental Engineering Organization (Ministry of Works &amp; Housing), New Delhi

*Members*SHRI B. B. RAU (*Alternate to*

Shri T. S. Swamy)

DR B. V. BHOOTA

SHRI N. BISWAS

SHRI R. C. P. CHAUDHARY

SHRI K. RUDRAPPA (*Alternate*)

CHIEF ENGINEER

SUPERINTENDING ENGINEER (*Alternate*)

CHIEF ENGINEER

SUPERINTENDING ENGINEER (*Alternate*)

CHIEF ENGINEER (WATER)

SHRI V. D. DESAI

SHRI M. Y. MADAN

SHRI C. E. S. RAO (*Alternate*)

PROF N. MAJUMDER

SHRI J. M. DAVE (*Alternate*)

SHRI S. R. MAJUMDER

SHRI A. M. LAHURI (*Alternate*)

SHRI R. GOVINDA MENON

SUPERINTENDING ENGINEER (EXECUTION) (*Alternate*)

SHRI R. N. MUKHERJEE

SHRI S. S. NAIK

SHRI H. D. PATEL (*Alternate*)

SHRI D. APPUKUTTAN NAIR

SHRI S. K. NEOGI

SHRI D. K. GHOSH (*Alternate*)All India Manufacturers' Organization, Bombay  
Directorate General of Technical Development,  
New Delhi

Engineers India Ltd New Delhi

Uttar Pradesh Jal Nigam, Lucknow

Public Health Engineering Department, Govern-  
ment of Jammu & Kashmir, Srinagar

Municipal Corporation of Delhi

Municipal Corporation of Greater Bombay

The Hindustani Construction Co Ltd, Bombay

National Environmental Engineering Research  
Institute (CSIR), Nagpur

Paterson Engineering Co (India) Ltd, Calcutta

Tamil Nadu Water Supply & Drainage Board,  
MadrasCalcutta Metropolitan Planning Organization,  
Calcutta

Hydraulic &amp; General Engineers Pvt Ltd, Bombay

Public Health Engineering Department, Govern-  
ment of KeralaInstitution of Public Health Engineers, India,  
Calcutta*(Continued on page 2)*

© Copyright 1977

INDIAN STANDARDS INSTITUTION

This publication is protected under the *Indian Copyright Act (XIV of 1957)* and reproduction in whole or in part by any means except with written permission of the publisher shall be deemed to be an infringement of copyright under the said Act.

## IS : 8413 (Part I) - 1977

(Continued from page 1)

### Members

SHRI K. RAMANNA  
COL RAJ KUMAR  
SHRI I. S. BEDI (*Alternate*)  
PROF S. SUBBA RAO  
  
SHRI A. V. RAO (*Alternate*)  
SHRI D. R. JAGANNATH RAO  
  
SHRI M. G. VAIDYA (*Alternate*)  
SHRI B. N. SEN  
  
SHRI T. N. CHATTERJEE (*Alternate*)  
SHRI J. L. SETHI  
  
SHRI L. M. CHAUDHARI (*Alternate*)  
SHRI M. L. SHAH  
SHRI M. J. SHETTY  
SHRI D. K. CHOUDHURY (*Alternate*)  
SHRI D. R. SINGAL  
  
SHRI S. A. SWAMY  
SHRI P. S. TENDOLKAR  
SHRI C. L. SASTRI (*Alternate*)  
SHRI C. VISWESWARIAH  
  
SHRI D. AJITHA SIMHA,  
Director (Civ Engg)

### Representing

Corporation of Madras  
Engineer-in-Chief's Branch, Army Headquarters  
  
All India Institute of Hygiene & Public Health,  
Calcutta  
  
Public Health Engineering Department, Govern-  
ment of Madhya Pradesh, Bhopal  
  
Department of Health, Government of West  
Bengal, Calcutta  
  
Public Health Engineering Department, Govern-  
ment of Haryana, Chandigarh  
  
Dorr Oliver India Ltd, Bombay  
Geo-Miller & Co, Calcutta  
  
Public Health Engineering Department, Govern-  
ment of Punjab, Chandigarh  
The Institution of Engineers (India), Calcutta  
Candy Filters (India) Ltd, Bombay  
  
Public Health Engineering Department, Govern-  
ment of Karnataka, Bangalore  
Director General, ISI (*Ex-officio Member*)

### Secretary

SHRI VINOD KUMAR  
Deputy Director (Civ Engg), ISI

## Waste Water Treatment Equipment Subcommittee, BDC 40 : 2

### Concener

DIRECTOR  
National Environmental Engineering Research  
Institute (CSIR), Nagpur

### Members

SHRI V. RAMAN (*Alternate to*  
Director, NEERI)  
SHRI R. R. SRI  
  
SHRI S. K. NEOGI (*Alternate*)  
SHRI O. P. BISHNOI  
SHRI R. S. SINGH (*Alternate*)  
DR R. N. CHAKRABARTY  
SHRI B. B. BHALLERAO (*Alternate*)  
SHRI M. Y. MADAN  
SHRI P. S. WADIA (*Alternate*)  
PROF B. L. MAHABAL  
SHRI R. V. S. MURTHY (*Alternate*)  
  
Institution of Public Health Engineers, India,  
Calcutta  
  
Uttar Pradesh Jal Nigam, Lucknow  
  
Engineers India Limited, New Delhi  
  
The Hindustan Construction Co Ltd, Bombay  
  
Victoria Jubilee Technical Institute, Bombay

(Continued on page 16)

# *Indian Standard*

## REQUIREMENTS FOR BIOLOGICAL TREATMENT EQUIPMENT

### PART I TRICKLING FILTERS

#### 0. FOREWORD

**0.1** This Indian Standard (Part I) was adopted by the Indian Standards Institution on 31 January 1977, after the draft finalized by the Public Health Engineering Equipment Sectional Committee had been approved by the Civil Engineering Division Council.

**0.2** A series of Indian Standards are being formulated to cover different types of equipment used in waste water treatment. For biological treatment of waste water under aerobic conditions several processes, such as trickling filters, activated sludge oxidation ditches, etc, are used.

**0.3** Trickling filters can be classified into two groups. The classification is according to applied hydraulic and organic loadings of settled waste water. Standard rate trickling filters have hydraulic loading between 525 to 2 100 m<sup>3</sup>/h/hectare while high rate trickling filters, including recirculation, have hydraulic loading between 4 200 to 15 000 m<sup>3</sup>/hectare. Organic loading for these two types of filters varies from 80 to 400 g/day/m<sup>3</sup> for the former and 400 to 4 800 g/day/m<sup>3</sup> for the latter. This standard does not, however, cover the design aspect of the trickling filters but has been intended to provide guidance regarding the equipment to be used for these filters.

**0.4** In the formulation of this standard due weightage has been given to international co-ordination among the standards and practices prevailing in different countries in addition to relating it to the practices in the field in this country.

**0.5** For the purpose of deciding whether a particular requirement of this standard is complied with, the final value, observed or calculated, expressing the result of a test or analysis, shall be rounded off in accordance with IS : 2-1960\*. The number of significant places retained in the rounded off value should be the same as that of the specified value in this standard.

---

#### 1. SCOPE

**1.1** This standard (Part I) covers requirements for equipment used in trickling filters.

---

\*Rules for rounding off numerical values (*revised*).

## 2. TERMINOLOGY

**2.0** For the purpose of this standard, the following definitions shall apply.

**2.1 Hydraulic Loading** — Total volume of liquid including recirculated flow, if any, per hour per unit surface area of filter bed. This is generally expressed in m<sup>3</sup>/h/hectare.

**2.2 Organic Loading** — Total weight of 5-day-20°C BOD applied per day per unit volume of filter media. This is generally expressed as g/day/m<sup>3</sup>.

**2.3 Recirculation Flow** — It is that part of the filter effluent which is recycled through the filter again.

**2.4 Recirculation Ratio** — It is the ratio of the recirculated flow to the average influent flow. Where two or more recirculation methods are used in the same design, the recirculation ratio shall be worked out by summing all flows recirculated through the filter to the average influent flow.

**2.5 Trickling Filter** — A filter consisting of an artificial bed of material as specified in Table 1 over which waste water is distributed and applied in drops, films or spray, from troughs, drippers, moving distributors or fixed nozzles and through which it trickles to the underdrains, giving opportunity for the formation of zoogeal film on the surface media.

## 3. MATERIALS

**3.1** The materials for components of trickling filter are indicated in Table 1.

**TABLE 1 MATERIALS FOR DIFFERENT COMPONENTS OF TRICKLING FILTERS**

Sl. No. (1)	COMPONENTS (2)	MATERIAL (3)	REFERENCE TO INDIAN STANDARDS (4)
1.	<i>Rotary Distributor</i>		
a)	Tie rods and turn-buckle	Mild Steel	IS : 226-1969*
b)	Turn table base	High grade cast iron	IS : 210-1970†
c)	Balls	Steel (high carbon)	IS : 226-1969*
d)	Removable inserts	Steel, hardened	—
e)	Revolving assembly	Cast steel	IS : 1030-1974‡
f)	Distribution arm	Mild steel (properly protected), cast iron and structural steel, fibre glass, hard PVC	IS : 1978-1971§ IS : 226-1969* IS : 1336-1967
g)	Iron ball, dozing siphon	} Cast iron	IS : 2107-1962¶
h)	Legs of dozing siphon		

\*Specification for structural steel (standard quality) (*fourth revision*).

†Specification for grey iron castings (*second revision*).

‡Specification for carbon steel castings for general engineering purposes (*second revision*).

§Specification for line pipe (*first revision*).

||Specification for centrifugally cast (spun) iron pressure pipes for water, gas and sewage (*revised*).

¶Specification for whiteheart malleable iron castings.

(Continued)



**TABLE 1 MATERIALS FOR DIFFERENT COMPONENTS OF TRICKLING FILTERS—Contd**

Sl. No.	COMPONENTS	MATERIAL	REFERENCE TO INDIAN STANDARDS
(1)	(2)	(3)	(4)
	j) Sniff pipe of dozing siphon	Structural steel	IS : 226-1969*
	k) Spreader, orifice plates	Copper	IS : 191-1967†
		Bronze	IS : 410-1967‡
		Brass	—
		Aluminium	IS : 736-1965§
		Stainless steel	IS : 1570 (Part V)-1972
	m) Seals	Mercury, chrome leather, nitrile rubber gasket	—
2.	<i>Filter</i>		
	Filter media	Granite, gneiss, basalt and trap, gravel, blast furnace slag, broken bricks of hard variety, ceramic hollow cylinders, plastic material, slate and blocks of inert materials	—
	Filter blocks	Vitrified clay or cement concrete	IS : 456-1964¶
	Support piers	Cement concrete	IS : 456-1964¶
	Drainage channel	Vitrified clay	—
		Cement concrete	IS : 456-1964¶
3.	<i>Civil Structure</i>	Cement concrete	IS : 456-1964¶ IS : 3370 (Part I)-1965** IS : 3370 (Part II)-1965** IS : 3370 (Part III)-1967** IS : 3370 (Part IV)-1967**

\*Specification for structural steel (standard quality) (*fourth revision*).

†Specification for copper (*second revision*).

‡Specification for rolled brass plate, sheet, strip and foil (*second revision*).

§Specification for wrought aluminium and aluminium alloys, plate (for general engineering purposes).

||Schedules for wrought steels for general engineering purposes: Part V Stainless steel and heat-resisting steels (*first revision*).

¶Code of practice for plain and reinforced concrete (*second revision*).

\*\*Code of practice for concrete structures for the storage of liquids:

Part I General requirements

Part II Reinforced concrete structures

Part III Prestressed concrete structures

Part IV Design tables

## 4. CONSTRUCTION AND MANUFACTURE

**4.1 Essential Parts** — Each trickling filter shall consist of the following essential parts:

- a) A rectangular or circular tank constructed of concrete or masonry with impervious floor,
- b) Underdrainage,
- c) Ventilators,
- d) Filter media, and
- e) Distributors.

**4.2 Civil Structures** — Floors shall be impervious. Dry packing of stones and bricks should not be used for construction of side walls.

### 4.3 Underdrainage System

**4.3.1 General** — Every trickling filter shall be provided with an underdrainage system for collection of effluent and ventilation. They all have three essential parts, namely, filter blocks to act as lateral drains, supporting piers for filter blocks, and main drainage channel.

**4.3.2 Filter Blocks** — These shall be precast solid or hollow concrete or vitrified clay units of rectangular or any other shape having openings on top face equal to 20 percent of the top surface area. Material specification for concrete should follow IS : 456-1964\*. Supporting piers are necessary for precast solid blocks but hollow blocks may be directly laid on the sloping floor. The height of the piers shall not be less than 10 mm. A typical diagram of filter block is given at Fig. 1.

**4.3.3 Main Collecting Channel** — The main collecting channel may be diametrically or peripherally located. It should be designed to flow half to three-fourths full at peak flow, with a velocity of 60 to 90 cm/s. The main collecting channel should be constructed with concrete (see IS : 456-1964\*) or brick or vitrified clay pipe or channels below the floor level and covered with slabs or filter blocks depending on width of the channel.

**4.3.4 Filter** shall be provided with arrangements for cleaning the underdrains.

**4.4 Ventilators** — The filter bed shall be provided with ventilators along the entire periphery of the filter at 200 cm centre-to-centre. They should be of a diameter greater than 100 mm and should be raised above the media top by 75 mm and covered with cowl.

### 4.5 Filter Media

**4.5.1** The material used for filter shall be durable under actual operating conditions. In order to satisfy this quality, they should be hard,

\*Code of practice for plain and reinforced concrete (second revision)

sound, insoluble in waste water and should be resistant to decomposition and disintegration when subject to continuous application of waste water and variation in temperature and other conditions. In cold climatic condition where water is subjected to freezing and thawing, natural stone media should be tested against disintegration by sodium sulphate test as described in Appendix A. Any media of which 10 percent by mass of the number of pieces tested fails or from which total material passing a 12.5 mm sieve (square openings) exceeds 10 percent of the total mass of the material tested, should be regarded as unsuitable. Media with high silica content should be tested to determine its soundness before use.

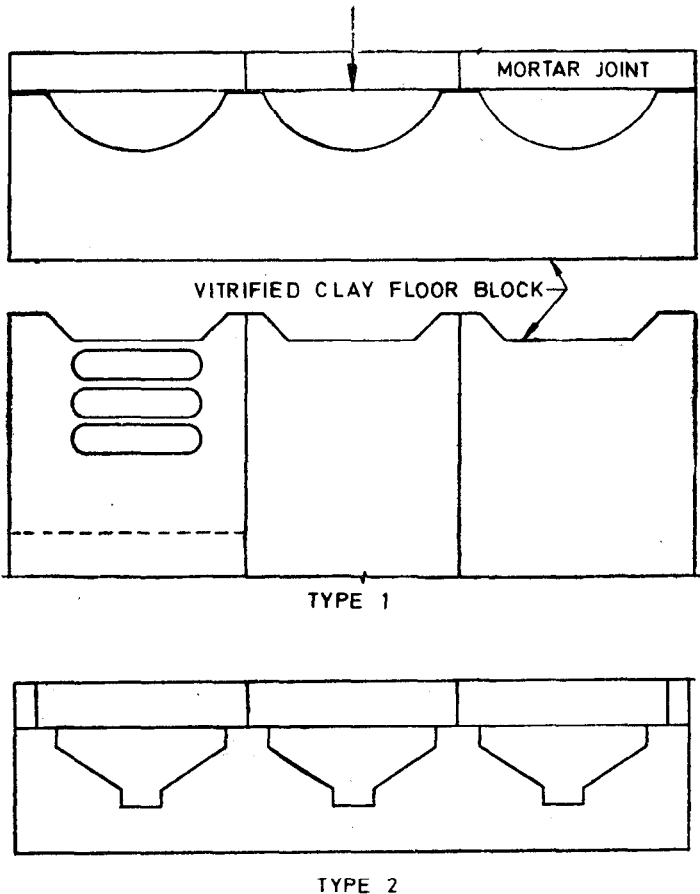

FIG. 1 TYPICAL DRAWING OF FILTER BLOCKS

**4.5.2** An ideal filter medium should also have a high surface area per unit volume and should not clog easily. The most suitable material is generally locally available crushed stone or gravel. Other materials, such as slag, cinders, hard coal have also been used.

**4.5.3 Size and Shape** — Media consisting of uniform size should be used in single layer treatment. In multi-layer treatment each layer should contain media of uniform size. The minimum thickness of each layer should be at least 6 times the dimension of the largest stone in the layer. The minimum void in any layer shall be at least 40 percent. Recommended sizes of natural media are within the range of 50 to 75 mm or 75 to 100 mm or 90 to 115 mm or 100 to 125 mm. It is recommended that not more than 5 percent of materials by volume be allowed for both upper and lower size limits. It is also recommended that as far as possible the three dimensions of the media pieces should be equal.

**4.5.4 Cleaning of Filter Materials** — All media shall be thoroughly cleaned with water before being placed in a filter bed to remove fines, dust, clay and other foreign matter.

**4.6 Distributors** — Waste water distributors are mainly of the following three types:

- a) Rotary distributors,
- b) Fixed-spray nozzles, and
- c) Longitudinal travelling distributors.

**4.6.1 Types of Rotary Distributors** — There are mainly two types of rotary distributors:

- a) Hydraulic-reaction-driven rotary — A typical sketch of rotary distributor is given in Fig. 2, and
- b) Motor-driven rotary.

**4.6.1.1 Hydraulic reaction driven rotary distributor** — It shall essentially consist of a central assembly which can revolve about the vertical axis. Two or more horizontal distribution arms are attached to this central assembly. Waste water is discharged through the orifices on one side of each of these arms. The reaction of the discharge from these orifices causes the arms to revolve about the vertical axis in a direction opposite to the discharge. Details of central assembly and distribution arms are given below:

- a) *Central assembly* — The central assembly consists of (1) stationary turntable base erected over a concrete pedestal at the centres of the filter, and (2) revolving assembly mounted on the stationary assembly. A typical sketch of central assembly is given in Fig. 3.
  - 1) *Stationary turntable base* — It shall be made of high grade cast iron (see IS: 210-1962\*) with provision for anchoring it to a pedestal with not less than six anchor bolts. This base shall be

---

\*Specification for grey iron castings (second revision).

provided with either one or two large diameter ball races consisting of high grade steel balls which run in an oil-bath. These balls shall be protected from dust and moisture by felt or other seals of suitable material. Removable inserts shall be used in the base to act as bearing surfaces for the walls. Provisions shall be made for draining and filling the oil-bath. A mercury seal or any other approved type arrangement to prevent contact of the bearing with waste water and short circuiting of the waste water shall be provided between the fixed base and the revolving assembly. Where a mercury seal is provided, arrangements shall be provided for (i) easy filling in of mercury, (ii) draining with a catch well, and (iii) locking arrangement on the drain line to prevent pilferage of the mercury. All seals shall be able to take care of differences in head and friction losses with a factor of safety of 3.

- 2) *Revolving assembly* — It shall consist of an assembly to revolve on the ball race and a hollow central column mounted thereon with outlet arrangements for fixing the distributor arms. The assembly shall be of cast iron as in the stationary base while the central column shall be of mild steel plate of thickness not less than 5 mm. The central column shall be so designed as to overflow before the seal fails.

Where distributor arms with double compartments are provided, the central column shall have suitable devices such as overflow rings to regulate the flow into the upper compartments whenever the flow reaches the maximum.

- b) *Distributor arms* — There shall be either two or four arms for distributing the waste water. The arms shall be of such size that the velocity of flow in them shall not be less than 0.6 m/s and shall not exceed 1.2 m/s. Each arm shall be provided with an end dump gate for quick flushing of the contents. The arms shall be fastened to the central column by means of leakproof flanged connections with gaskets. The arms shall also be connected to the adjacent arms as well as the central columns with necessary guy rods, turnbuckles and the tie rods for strength and balance. When two distributor arms are provided two more dummy stub arms shall be provided for stability or equilibrium purposes. The thickness of the mild steel or fabricated steel used in the arms shall not be less than 5 mm. The distribution arms may be of circular or near rectangular cross sections with single or double compartments one above the other. For small flows, pipe arms may be provided. Where fabricated distributor arms are provided the cross section of the arms shall be progressively smaller from the centre of the filter to the periphery to maintain constant velocity of flow as the flow is progressively decreasing towards the periphery. The arms shall be placed 150 to 300 mm above the top of the filter media.

The waste water shall be evenly distributed over the entire top surface of the filter bed by means of orifices and nozzles placed suitably along one side of the arm. The flow sprayed by each orifice shall be regulated by a non-ferrous metal deflector plate or spreader of minimum 3 mm thickness, fixed to the distributor arm, under the orifice plates. There shall be two orifice plates overlapping each other for each orifice, made of non-ferrous or similar material with slot openings to enable accurate adjustment of area of orifice for regulating the flow from each orifice. A rubber gasket shall be provided between the orifice in the arm and the orifice plates. The orifice plates and the spreaders shall be fastened to the distributor arms by means of non-ferrous bolts and nuts for easy assembly and dismantling for maintenance purposes. The nozzles where provided, shall be of the reaction type designed for optimum distribution of the spacing. The rotary distributor shall discharge its contents over the filter media in proportion to the annular areas covered by each successive distributor length from the centre.

The opening of the orifices or the nozzles shall be so designed as to compensate for the differential head resulting from loss due to velocity friction, etc, and gain due to centrifugal force causing rotation of arm and part recovery of velocity head. The minimum size of the orifice shall be 16 mm.

**4.6.1.2 Motor driven rotary distributor** — They shall be similar to the reaction type distributor in construction except that the arms shall be rotated by means of a motor plus reduction gear. The motor shall have a fixed speed. The motor shall comply with the requirements of IS : 325-1970\* or IS : 996-1964† whichever is applicable. When the motor is located at the centre of the filter next to the turntable, a walkway shall be provided for access in such a manner as to permit access to the centre of the filter bed even with the distributor arms rotating.

**4.6.1.3 Speed of rotary distributors** — Generally two and four arms distributors are rotated at 2 and 1.4 rev/min respectively. However, the speed of the rotary distributor shall be within the approved maximum and minimum range as agreed to between the manufacturer and the purchaser and these speeds shall not be exceeded or decreased at maximum and minimum flows.

**4.6.2 Fixed Spray Nozzles Distributors** — The system consist of a series of spray nozzles located at the apexes of equilateral triangles covering the filter bed (see Fig. 4). A pipe network distributes the waste water uniformly to the nozzles. Special nozzles having a flat spray pattern are used. Nozzles normally throw a spray so as to cover an annular area. Since the head on the nozzles is decreased in a predetermined manner as the waste water level in the dozing tank is drawn down, the diameter of

\*Specification for three-phase induction motors (third revision).

†Specification for single-phase small ac and universal electric motors (revised).

the spray covered is reduced at such a rate that the entire area within the maximum diameter is dozed evenly.

**4.6.3 Travelling Distributors** — This is applicable to rectangular beds. A common type of travelling distributor consists of a trough supported by truss resting on a truck that runs on a rail on either side of the filter bed. Waste water is fed into the trough through a siphon attached to the moving distributor and from a fixed trough parallel to the rail. The waste water is fed from the travelling trough by jets similar to those from the revolving distributor arm. They may be self-propelled or motor driven.

## 5. DOZING SIPHONS

**5.1** Dozing siphons are necessarily provided for the standard rate filter with fixed nozzle distributors to provide intermittent spray of waste water. They are also used at plants where wide variations occur in gravity flow to reaction type rotary distributors. Such tanks provide the minimum head required to keep the distributor in operation. Recirculation during minimum flow periods is a better device than dozing siphons for this purpose. When a dozing siphon is provided it shall consist of bell supported on legs anchored to dozing tank floor. Cast iron feed and overflow pipe above the tank floor shall be provided. Mild steel control pipe with cast iron fittings shall be used between siphon bell and overflow pipe. The siphon shall be provided with a sniff pipe to permit air entry. The sniff pipe shall be provided with mild steel guard. The size of the siphon tank (dozing tank) shall be such that it provides a minimum of 2 minutes or preferably  $2\frac{1}{2}$  minutes detention at maximum flow rate. The drawdown shall be of the order of 250 to 300 mm. The tank shall not be less than 150 mm below low water level. The dozing tank with siphon shall be placed at such an elevation so that the high water level in the tank shall be not less than 600 to 1 350 mm above the level of orifice in distribution arm and the low water level be high enough to furnish head to propel the distributor, usually at least 300 mm above the level of the distribution orifices. The corresponding values may be 3 m and 1.5 m respectively for dozing tanks installed for standard rate filter with fixed nozzle spray. A typical diagram of dozing siphon is given in Fig. 5.

## 6. PAINTING

**6.1 Painting** — All steel surfaces to be painted shall be thoroughly dried and freed from rust and grease. A suitable anticorrosive primer shall be used for painting. One coat of primer and at least three coats of bitumastic or other anticorrosive paints shall be used after erection [see IS : 1477-(Part I)-1971\* and IS : 1477 (Part II)-1971†]. Alternatively the use of epoxy or similar coating may be considered.

\*Code of practice for painting of ferrous metals in buildings: Part I Pretreatment (first revision).

†Code of practice for painting of ferrous metals in buildings: Part II Painting (first revision).

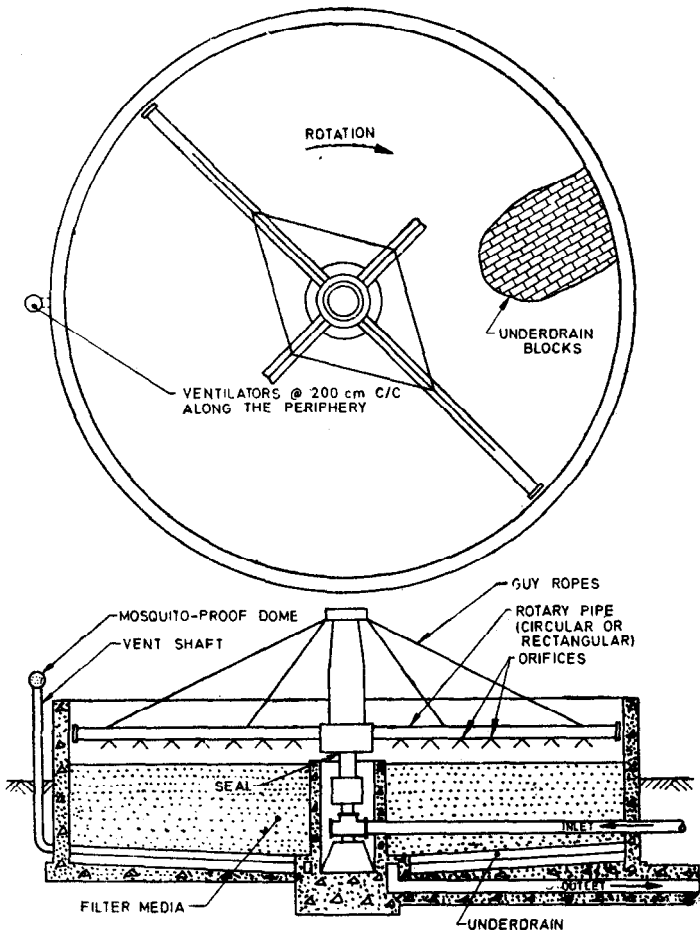

2A Trickling Filter with Rotary Distributor

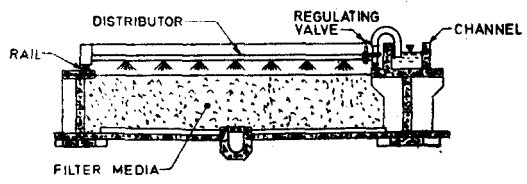

2B Travelling Distributor

FIG. 2 DISTRIBUTOR GENERAL ARRANGEMENT



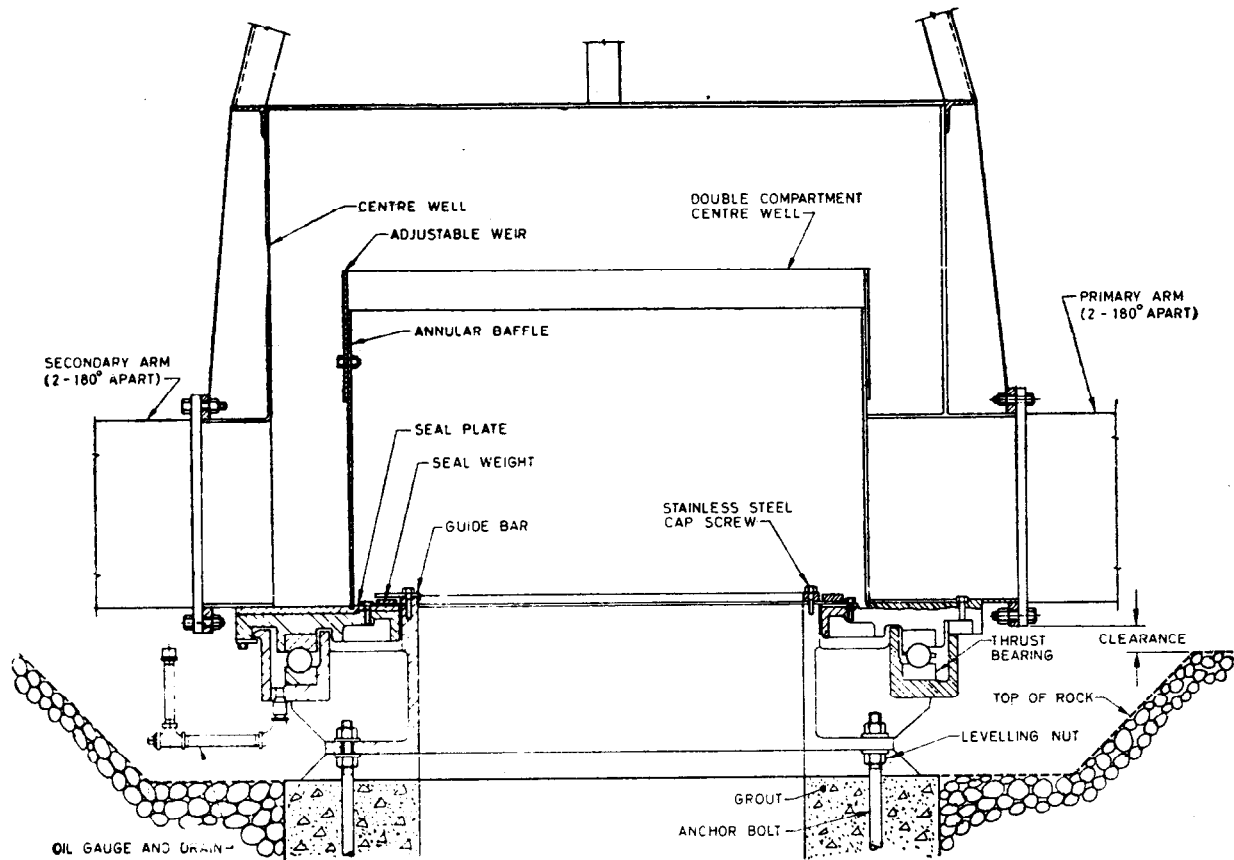

FIG. 3 ROTARY DISTRIBUTOR CENTRE ASSEMBLY

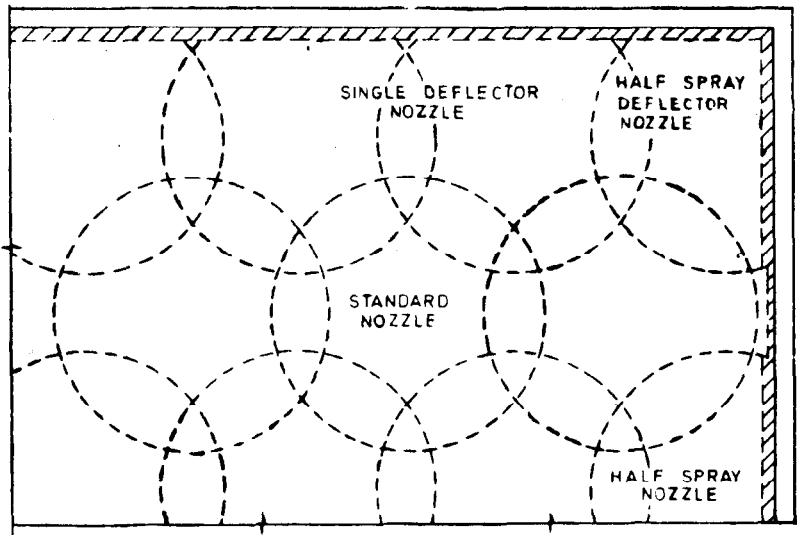
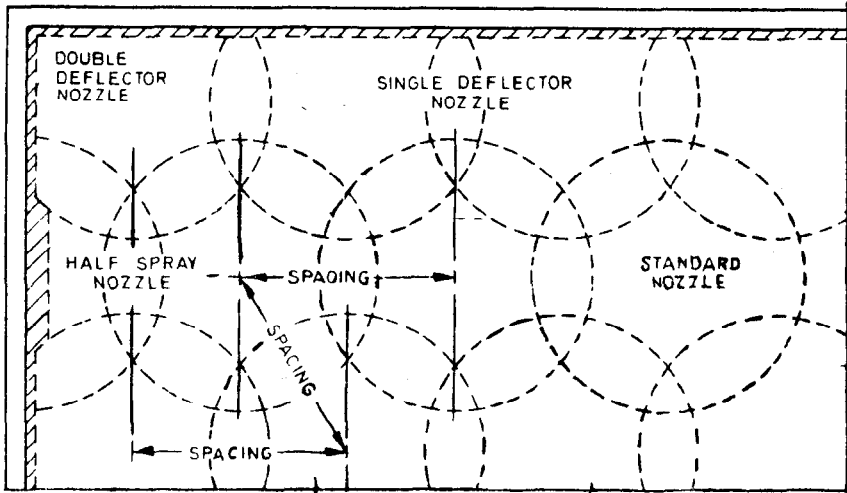

FIG. 4 GENERAL ARRANGEMENT OF STATIONARY SPRAY NOZZLES

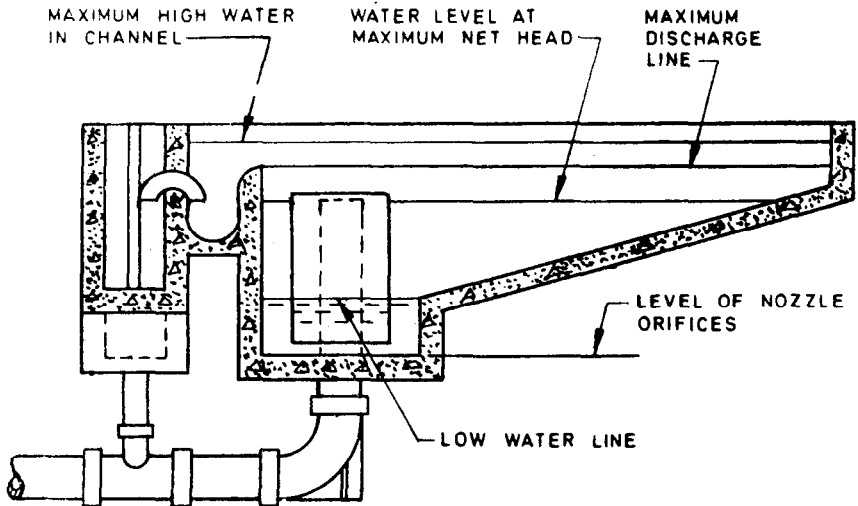

FIG. 5 TYPICAL SECTION OF A DOZING TANK

## APPENDIX A

(Clause 4.5.1)

### SODIUM SULPHATE TEST ON FILTER MEDIA

#### A-1. TEST PROCEDURE

**A-1.1** Minimum of ten pieces are picked up at random and are dried at  $105 \pm 5^\circ\text{C}$  for 4 hours and weighed. Sodium sulphate solution (concentrated, 400 g/litre) is then added to completely immerse all the pieces in a container and the temperature of solution adjusted to  $20^\circ\text{C}$  to  $30^\circ\text{C}$ . The pieces are then left immersed in the solution for 16 to 18 hours. These are then removed, and first air dried for half-an-hour and then dried in an oven at  $105 \pm 5^\circ\text{C}$  for 4 hours. They are then cooled for 1 hour. The test is repeated for 20 times in case of samples from media for the top 450 mm depth and 10 times in case of samples from remaining depth of media.

After repeating the tests as stated above the samples are sieved on a square mesh of 12.5 mm opening. Those pieces passing through the mesh are collected and weighed.

**IS : 8413 (Part I) - 1977**

(Continued from page 2)

<i>Members</i>	<i>Representing</i>
SHRI U. C. MANKAD	Geo Miller & Co, New Delhi
SHRI D. K. CHAUDHARY ( <i>Alternate</i> )	
SHRI H. N. MISRA	EIMCO-KCP Ltd, Madras
SHRI S. S. NAIK	Hydraulic & General Engineers Pvt Ltd, Bombay
SHRI H. D. PATEL ( <i>Alternate</i> )	
SHRI D. APPUKUTTAN NAIR	Public Health Engineering Department, Government of Kerala, Trivandrum
SHRI K. RAMACHANDRAN ( <i>Alternate</i> )	
SHRI N. L. PATEL	Municipal Corporation of Greater Bombay
SHRI G. F. KHAMBATTI ( <i>Alternate</i> )	
DR S. RAMACHANDRA	Central Mechanical Engineering Research Institute (CSIR), Durgapur
SHRI S. NATARAJAN ( <i>Alternate</i> )	
SHRI M. L. SHAH	Dorr Oliver India Ltd, Bombay
SHRI V. W. KALE ( <i>Alternate</i> )	
PROF S. SUBBA RAO	All India Institute of Hygiene & Public Health, Calcutta
SHRI A. V. RAO ( <i>Alternate</i> )	