

इंटरनेट

मानक

Disclosure to Promote the Right To Information

Whereas the Parliament of India has set out to provide a practical regime of right to information for citizens to secure access to information under the control of public authorities, in order to promote transparency and accountability in the working of every public authority, and whereas the attached publication of the Bureau of Indian Standards is of particular interest to the public, particularly disadvantaged communities and those engaged in the pursuit of education and knowledge, the attached public safety standard is made available to promote the timely dissemination of this information in an accurate manner to the public.

“जानने का अधिकार, जीने का अधिकार”

Mazdoor Kisan Shakti Sangathan

“The Right to Information, The Right to Live”

“पुराने को छोड़ नये के तरफ”

Jawaharlal Nehru

“Step Out From the Old to the New”

IS 7196 (1974): Specification for hold fast [CED 15: Builder Hardware]



“ज्ञान से एक नये भारत का निर्माण”

Satyanarayan Gangaram Pitroda

“Invent a New India Using Knowledge”



“ज्ञान एक ऐसा खजाना है जो कभी चुराया नहीं जा सकता है”

Bhartrhari—Nitiśatakam

“Knowledge is such a treasure which cannot be stolen”

BLANK PAGE



IS : 7196 -1974
(Reaffirmed 2007)

Indian Standard

SPECIFICATION FOR
HOLD FAST

(Second Reprint NOVEMBER 1998)

UDC 683.356 : 69.028.1/.2

© *Copyright* 1974

BUREAU OF INDIAN STANDARDS
MANAK BHAVAN, 9 BAHADUR SHAH ZAFAR MARG
NEW DELHI 110 002

Indian Standard

SPECIFICATION FOR HOLD FAST

Builder's Hardware Sectional Committee, BDC 15

<i>Chairman</i>	<i>Representing</i>
SHRI YUSUF MOWJEE	M.C. Mowjee & Company, Calcutta; and Builder's Hardware Industries Association of India Calcutta
<i>Members</i>	
SHRI SAHIB SINGH (<i>Alternate to Shri Yusuf Mowjee</i>)	Gobindo Sheet Metal Works and Foundry, Calcutta
SHRI AJOYENDU PAUL	Engineer-in-Chief's Branch, Army Headquarters
SHRI D. R. BAHL	
SHRI J. L. KAPOOR (<i>Alternate</i>)	Institution of Engineers (India), Calcutta
SHRI J. P. BAJAJ	Indian Institute of Architects, Bombay
SHRI AJAY BHARADWAJ	
SHRI B. D. KSHIRSAGAR (<i>Alternate</i>)	Vertex Manufacturing Company Limited, Bombay
SHRI A. K. BHIMANI	
SHRI H. C. SAMPAT (<i>Alternate</i>)	Indian Aluminium Company Limited, Calcutta
SHRI R. M. CHAUDHRI	
SHRI J. K. ANAND (<i>Alternate</i>)	Railway Board (Ministry of Railways)
CONTROLLER OF STORES, EASTERN RAILWAY	
SHRI P. K. DE	De's Lock Industries, Calcutta
SHRI K. P. JAIN	Engineering Association of India, Calcutta
SHRI V. S. KAMBOJ*	Jayna Trading Corporation, Delhi
SHRI J. R. KANBARA	Arvind Industries, Jamnagar (Gujarat)
SHRI S. C. KAPOOR	Directorate General of Supplies & Disposals (Ministry of Supply)
SHRI S. D. MAJUMDAR	National Test House, Calcutta
DR A. V. R. RAO	National Buildings Organization, New Delhi
SHRI O. P. RATRA (<i>Alternate</i>)	
SHRI T. C. SOLANKI	Sen-Harvic, Bombay
SHRI N. K. RAGOOWANSHI (<i>Alternate</i>)	
SURVEYOR OF WORKS (I)	Central Public Works Department, New Delhi
SHRI D. AJITHA SIMHA, Director (Civ Engg)	Director General, ISI (<i>Ex-officio Member</i>)

Secretary

SHRI S. P. MAGOU
Assistant Director (Civ Engg), ISI

*He also represents Arvind Industries, Jamnagar (Gujarat) as alternate member.

(Continued on page 2)

● Copyright 1974

BUREAU OF INDIAN STANDARDS

This publication is protected under the *Indian Copyright Act (XIV of 1957)* and reproduction in whole or in part by any means except with written permission of the publisher shall be deemed to be an infringement of copyright under the said Act.

IS : 7196 - 1974

(Continued from page 1)

Door and Window Fittings Subcommittee, BDC 15 : 1

Convener

SHRI YUSUF MOWJEE

Representing

M. C. Mowjee & Company, Calcutta

Members

**SHRI SAHIB SINGH (Alternate to
Shri Yusuf Mowjee)**

SHRI AJOYENDU PAUL

SHRI A. K. BHIMANI

SHRI H. C. SAMPAT (Alternate)

SHRI P. BOSE

SHRI J. P. JAIN

SHRI M. R. JOSHI

**Gobindo Sheet Metal Works and Foundry, Calcutta
Vertex Manufacturing Company Limited, Bombay**

C. K. Sirkar & Company, Calcutta

Indian Hardware Industries Limited, New Delhi

**Department of Defence Production (Ministry of
Defence)**

SHRI S. SESHADRI (Alternate)

SHRI V. S. KAMBOJ

SHRI BIPIN KUMARIA

SHRI L. S. KUMAWAT

SHRI S. BALAKRISHNAN (Alternate)

SHRI N. V. SHASTRI

SURVEYOR OF WORKS (I)

Jayna Trading Corporation, Delhi

Chemi Chrome Industries Private Limited, Kanpur

Engineer-in-Chief's Branch, Army Headquarters

Railway Board (Ministry of Railways)

Central Public Works Department, New Delhi

AMENDMENT NO. 1 FEBRUARY 1979
TO
IS:7196-1974 SPECIFICATION FOR HOLD FAST

Alteration

(Page 3, clause 1.1)- Substitute the following for the existing clause:

'1.1 This standard lays down requirements for mild steel hold fasts for use with wooden door and window frames.'

(BDC 15)

Reprography Unit, BIS, New Delhi, India

**AMENDMENT NO. 2 JANUARY 2008
TO
IS 7196 : 1974 SPECIFICATION FOR HOLD FAST**

(Page 3, clause 0.4) — Delete the second sentence.

(CED 15)

Reprography Unit, BIS, New Delhi, India

Indian Standard

SPECIFICATION FOR HOLD FAST

0. FOREWORD

0.1 This Indian Standard was adopted by the Indian Standards Institution on 25 January 1974, after the draft finalized by the Builder's Hardware Sectional Committee had been approved by the Civil Engineering Division Council.

0.2 For the installation of door and window frames at the required place, hold fasts are provided on either side of the frames to anchor them in position. Hold fasts are manufactured in the country extensively and this standard is being issued to cover their basic requirements.

0.3 In the formulation of this standard due weightage has been given to international co-ordination among the standards and practices prevailing in different countries in addition to relating it to the practices in the field in this country.

0.4 This standard is one of a series of Indian Standards on builder's hardware. Other standards published so far in the series are given at P 6.

0.5 For the purpose of deciding whether a particular requirement of this standard is complied with, the final value, observed or calculated, expressing the result of a test or analysis, shall be rounded off in accordance with IS : 2-1960*. The number of significant places retained in the rounded off value should be the same as that of the specified value in this standard.

1. SCOPE

1.1 This standard lays down requirements for mild steel hold fasts.

2. MATERIAL

2.1 Mild Steel Flats — Mild steel flats shall conform to IS : 1731-1971†.

3. SIZE AND DIMENSIONS

3.1 The size and dimensions for the hold fast shall be as given in Fig. 1.

*Rules for rounding off numerical values (*revised*).

†Dimensions for steel flats for structural and general engineering purposes (*first revision*).

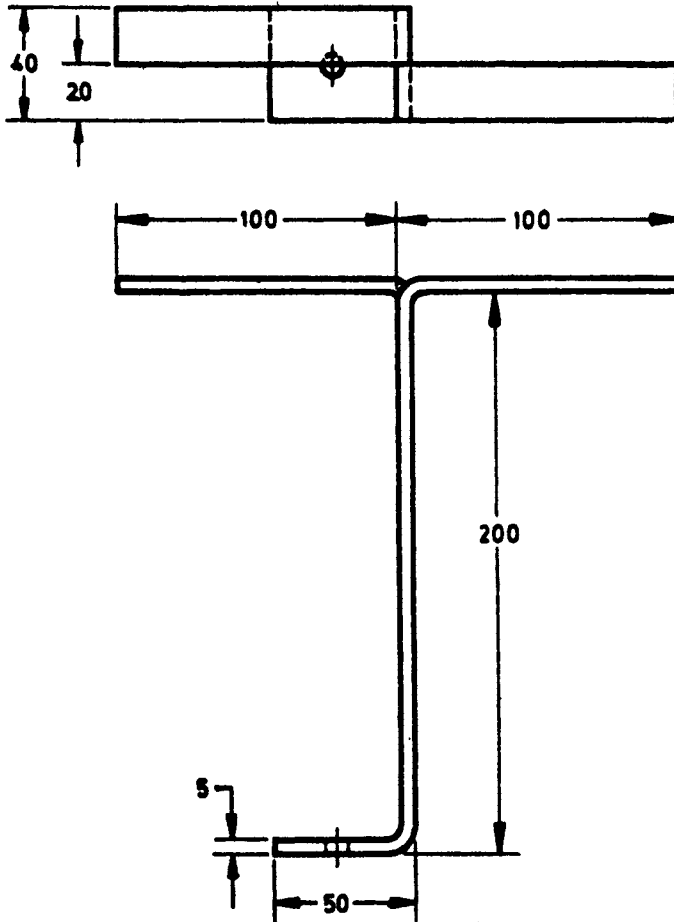

All dimensions in millimetres.

FIG. 1 MILD STEEL HOLD FAST

4. MANUFACTURE

4.1 The hold fasts shall be made from mild steel flats not less than 5 mm thick and without any burrs or dents.

5. FINISH

5.1 Hold fasts shall be given a coat of bitumen and sanded.

6. MARKING

6.1 Each hold fast shall be clearly and permanently marked with the name of the manufacturer or his trade-mark, if any.

6.1.1 The product may also be marked with Standard mark.

6.2 The use of the Standard Mark is governed by the provisions of the *Bureau of Indian Standards Act, 1986* and the Rules and Regulations made thereunder. The details of conditions under which the licence for the use of Standard Mark may be granted to manufacturers or producers may be obtained from the Bureau of Indian Standards.

BUREAU OF INDIAN STANDARDS

Headquarters

Manak Bhavan, 9 Bahadur Shah Zafar Marg, NEW DELHI 110002
Telephones 323 0131, 323 3375, 323 9402
Fax 91 11 3234062, 91 11 3239399, 91 11 3239382

Telegrams Manaksanstha
(Common to all Offices)

Central Laboratory

Plot No 20/9, Site IV, Sahibabad Industrial Area, Sahibabad 201010 Telephone 8-77 00 32

Regional Offices:

Central Manak Bhavan, 9 Bahadur Shah Zafar Marg, NEW DELHI 110002 323 76 17
*Eastern 1/14 CIT Scheme VII M, V I P Road, Maniktola, CALCUTTA 700054 337 86 62
Northern SCO 335-336, Sector 34-A, CHANDIGARH 160022 60 38 43
Southern C I T Campus, IV Cross Road, CHENNAI 600113 235 23 15
†Western Manakalaya, E9 Behind Marol Telephone Exchange, Andheri (East), MUMBAI 400093 832 92 95

Branch Offices:

Pushpak, Nurmohamed Shaikh Marg, Khanpur, AHMEDABAD 380001 550 13 48
‡Peenya Industrial Area, 1st Stage, Bangalore-Tumkur Road, BANGALORE 560058 839 49 55
Gangotri Complex, 5th Floor, Bhadbhada Road, T T Nagar, BHOPAL 462003 55 40 21
Plot No 62-63, Unit VI, Ganga Nagar, BHUBANESHWAR 751001 40 36 27
Kalaikathir Buildings, 670 Avinashi Road, COIMBATORE 641037 21 01 41
Plot No 43, Sector 16 A, Mathura Road, FARIDABAD 121001 8-28 88 01
Savitri Complex, 116 G T Road, GHAZIABAD 201001 8-71 19 96
53/5 Ward No 29, R G Barua Road, 5th By-lane, GUWAHATI 781003 54 11 37
5-8 56C, L N Gupta Marg, Nampally Station Road, HYDERABAD 500001 20 10 83
E-52, Chitaranjan Marg, C- Scheme, JAIPUR 302001 37 29 25
117/418 B, Sarvodaya Nagar, KANPUR 208005 21 68 76
Seth Bhawan, 2nd Floor, Behind Leela Cinema, Naval Kishore Road, LUCKNOW 226001 23 89 23
NIT Building, Second Floor, Gokulpat Market, NAGPUR 440010 52 51 71
Patliputra Industrial Estate, PATNA 800013 26 23 05
Institution of Engineers (India) Building 1332 Shivaji Nagar, PUNE 411005 32 36 35
T C No 14/1421, University P O Palayam, THIRUVANANTHAPURAM 695034 6 21 17

*Sales Office is at 5 Chowringhee Approach, P O Princep Street, CALCUTTA 700072 27 10 85
†Sales Office is at Novelty Chambers, Grant Road, MUMBAI 400007 309 65 28
‡Sales Office is at 'F' Block, Unity Building, Narashimaraja Square, BANGALORE 560002 222 39 71